



# 4UP 10-SLOT GEN4



## INSTALLATION GUIDE

4UP 10-SLOT Gen4



**OSS**  
ONE STOP SYSTEMS

# Table of Contents

<b>1</b>	<b>General Specifications .....</b>	<b>5</b>
1.1	Features .....	6
1.2	4UP Architecture (10 Slot).....	6
1.3	PCIe Slots .....	7
1.4	Backplane Block Diagram .....	7
1.5	Dimensions.....	8
1.6	Parts Overview .....	9
1.7	HIB x16 Gen 4 Card .....	11
1.8	Backplane.....	12
1.9	Slot Configurations.....	13
1.10	Use Case Diagrams .....	15
<b>2</b>	<b>Getting Started .....</b>	<b>17</b>
<b>3</b>	<b>Installation Overview .....</b>	<b>17</b>
<b>4</b>	<b>Remove Top Cover .....</b>	<b>18</b>
<b>5</b>	<b>Target Card Installation .....</b>	<b>18</b>
5.1	Target Card Configuration.....	19
<b>6</b>	<b>Host Card Installation.....</b>	<b>20</b>
6.1	Host Card Configuration.....	20
6.2	Dip switch Settings.....	22
<b>7</b>	<b>GPU / PCIe Cards Installation .....</b>	<b>23</b>
7.1	Install PCIe card / GPUs.....	24
7.2	Connect Aux Power Cables.....	24
7.3	Auxiliary Cable Management .....	25
<b>8</b>	<b>Connect Link Cables .....</b>	<b>26</b>
8.1	Mini-SAS HD SFF-8644 Cable Installation .....	26
8.1.1	x16 Configuration: FOUR cables .....	26
8.1.2	x8 Configuration: TWO cables .....	27
8.1.3	x4 Configuration: ONE cable.....	28
8.2	Disconnecting Mini-SAS HD SFF-8644 Cable.....	29
<b>9</b>	<b>Applying Power Correctly.....</b>	<b>30</b>
9.1	Connecting to electrical outlet.....	30
9.2	Connect Power Cords.....	30
<b>10</b>	<b>Powering UP the Computer .....</b>	<b>32</b>
<b>11</b>	<b>Hardware Check.....</b>	<b>33</b>
11.1	Verify Board LEDs .....	33
11.2	Fault LEDs (RED).....	34

11.3	Verify Adapter Card LEDs.....	35
11.4	Adapter Card LED Definitions .....	36
11.5	Slot LEDs .....	36
11.6	Power Distribution Board LED .....	37
11.7	Front LED .....	37
11.8	Power Supply LED Indicator .....	38
<b>12</b>	<b>Software Installation.....</b>	<b>39</b>
12.1	Software Driver Installation .....	39
<b>13</b>	<b>Verify HIB Device .....</b>	<b>40</b>
13.1	Linux OS .....	40
13.2	Windows 10 / Server .....	41
13.2.1	HIB Cards and Backplane .....	41
<b>14</b>	<b>Verify PCIe cards .....</b>	<b>43</b>
14.1	Linux .....	43
14.2	Windows.....	44
<b>15</b>	<b>IPMI .....</b>	<b>46</b>
15.1	Connect Ethernet Cables .....	46
15.2	Locate Mac Address & IP Address.....	47
15.3	Start Internet browser .....	48
<b>16</b>	<b>Important Technical Information.....</b>	<b>49</b>
16.1	Upstream and Downstream Slots .....	49
16.2	Slot LEDs .....	49
16.3	Board LEDs.....	50
16.4	Slot Type .....	50
16.5	PS_ON.....	50
16.6	ARF6 Connector .....	51
16.7	Slot Number and Port Mapping .....	51
16.8	Power Cords .....	52
16.8.1	Specifications .....	52
16.8.2	Power cord socket and voltage tables .....	52
16.9	Power Supply .....	53
16.9.1	Removing AC Power Supply.....	54
16.9.2	Specifications .....	55
16.9.3	LED Indicator .....	56
16.10	Fan .....	57
16.10.1	Fan Specifications .....	57
16.10.2	How to remove Fan.....	58
16.11	Fan Foam Air Filter .....	58
16.12	Auxiliary power cables .....	59

16.12.1	Aux power cable installation .....	60
16.12.2	Pin Outs.....	61
16.12.3	Using the Auxiliary Power Cable .....	63
16.13	Expansion Unit Power Consumption .....	65
16.14	Power consumption breakdown per hardware .....	65
<b>17</b>	<b>Troubleshooting.....</b>	<b>66</b>
17.1	Device is not detected or recognized.....	66
17.2	My PCIe devices are showing UP with a Yellow Exclamation mark.....	66
17.3	No link between host and target cards.....	66
17.4	Broken OSS-Backplane.....	66
17.5	My PCIe cards are not detected.....	66
<b>18</b>	<b>How to Get More Help .....</b>	<b>67</b>
18.1	Contacting Technical Support .....	67
18.2	Returning Merchandise .....	67
18.3	Third Party Hardware & Software Support Policy.....	67
18.4	Online Support Resources .....	67

# 1 General Specifications

Item	Description
<b>Enclosure</b>	Dimensions: 17.2" x 7" x 18.5" (4U) Net weight 38 lbs
<b>Host Options</b>	1x PCIe x4 x16 Host-to-Target uplink (32GB/s) 2x PCIe x4 x16 Host-to-Target uplinks (64GB/s) 4x PCIe x4 x16 Host-to-Target uplinks (128 GB/s) SmartNIC Host
<b>Backplane Options</b>	Single OSS-538: <ul style="list-style-type: none"> <li>1x single-width PCIe 4.0 x 16 FHFL upstream slot</li> <li>4x dual-width PCIe 4.0 x16 FHFL downstream slots</li> </ul> Dual OSS-538: <ul style="list-style-type: none"> <li>1x single-width PCIe 4.0 x 16 FHFL upstream slot</li> <li>4x dual-width PCIe 4.0 x16 FHFL downstream slots</li> </ul>
<b>Additional Slot Options</b>	Standard <ul style="list-style-type: none"> <li>Modifies one dual-width PCIe 4.0 x16 FHFL downstream slot to two single-width PCIe 4.0 x16 FHFL downstream slots per backplane</li> </ul> Riser <ul style="list-style-type: none"> <li>Adds and additional single-width PCIe 4.0 PCIe 4.0 FHFL downstream slot per backplane</li> </ul> Linked <ul style="list-style-type: none"> <li>Links two backplanes together so all slots are downstream to a single upstream</li> </ul>
<b>Cooling</b>	Operational Temperature: 0-35°C Operational Humidity: 10-90% relative humidity Operational Altitude: 0-10,000 feet above sea level Storage Temperature: -40°C - 71°C Fans: <ul style="list-style-type: none"> <li>3x 180CFM 120mm fans</li> <li>Default PWM controlled based on built-in temperature sensors</li> <li>Optional IPMI system monitoring and control</li> </ul>
<b>Power Options</b>	Single/ Dual AC 1600W Single/Dual DC 1600W
<b>System Monitoring</b>	Default - automatic dynamic temperature based fan speed control Optional—IPMI system monitoring with power, temperature, and fan speed control and monitoring
<b>Fan Filters</b>	Optional Quadra foam 45 PPI Replaceable Fan Filters
<b>PCIe 4.0 Cable Lengths</b>	1m 2m 3m
<b>Power Cords</b>	6' US 110V 6' US 240V 6' UK 2' IEC 6' IEC
<b>Agency Compliance</b>	Agency Certifications (testing pending): <ul style="list-style-type: none"> <li>FCC Class A</li> <li>CE Safety &amp; Emissions</li> <li>UL, cUL</li> <li>RoHS3</li> </ul>
<b>Warranty</b>	1 Year Return to Factory. Extended Warranty is available and sold separately. Upon purchased of a new unit you can buy an extended warranty.
<b>Operating System Supported</b>	Windows 10, Windows Server and Linux based OS

### 1.1 Features

- PCIe Gen4 architecture
- Semi-rugged frame design
- Dynamic fan speed control
- Configurable slot and host uplinks to optimize throughput
- Integrated IPMI based system monitoring
- AC and DC power inlet options

### 1.2 4UP Architecture (10 Slot)

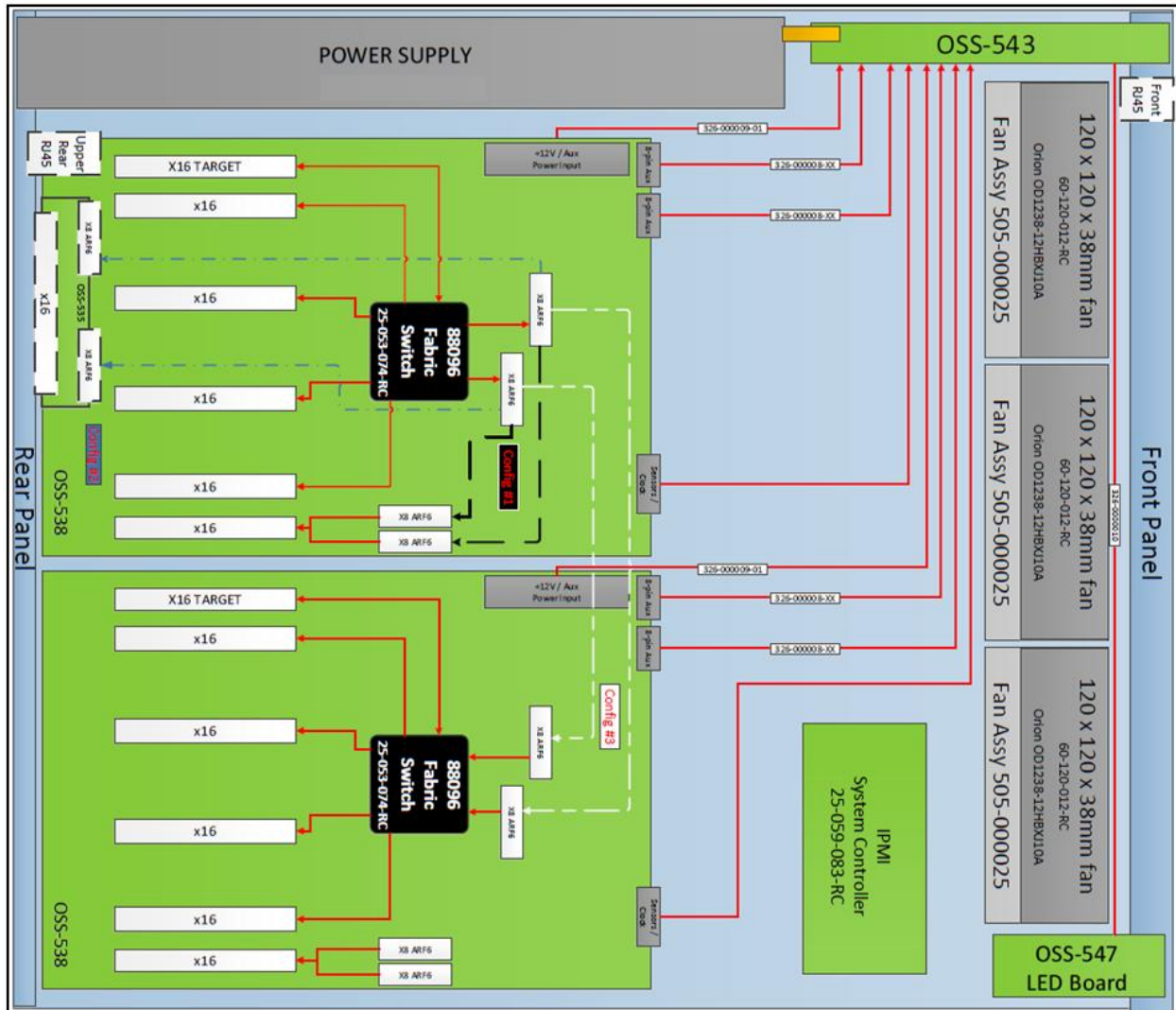

### 1.3 PCIe Slots

Slot Type: Closed-ended PCIe slot / connector, all the slots are x16 mechanical.

- Six x8 electrical slots (slots 1, 2, 3, 4, 5 and 6)
- Three x16 electrical slots(slots 0, 7 and 8)

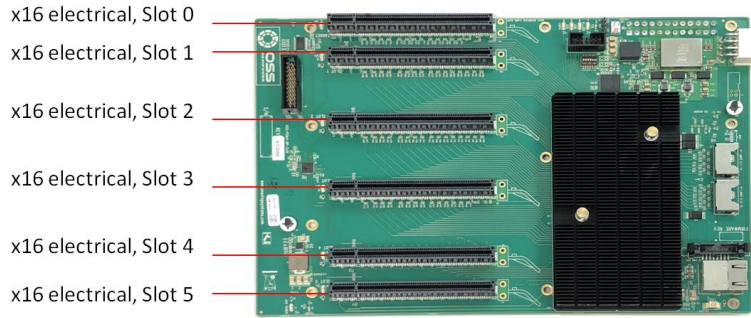

### 1.4 Backplane Block Diagram

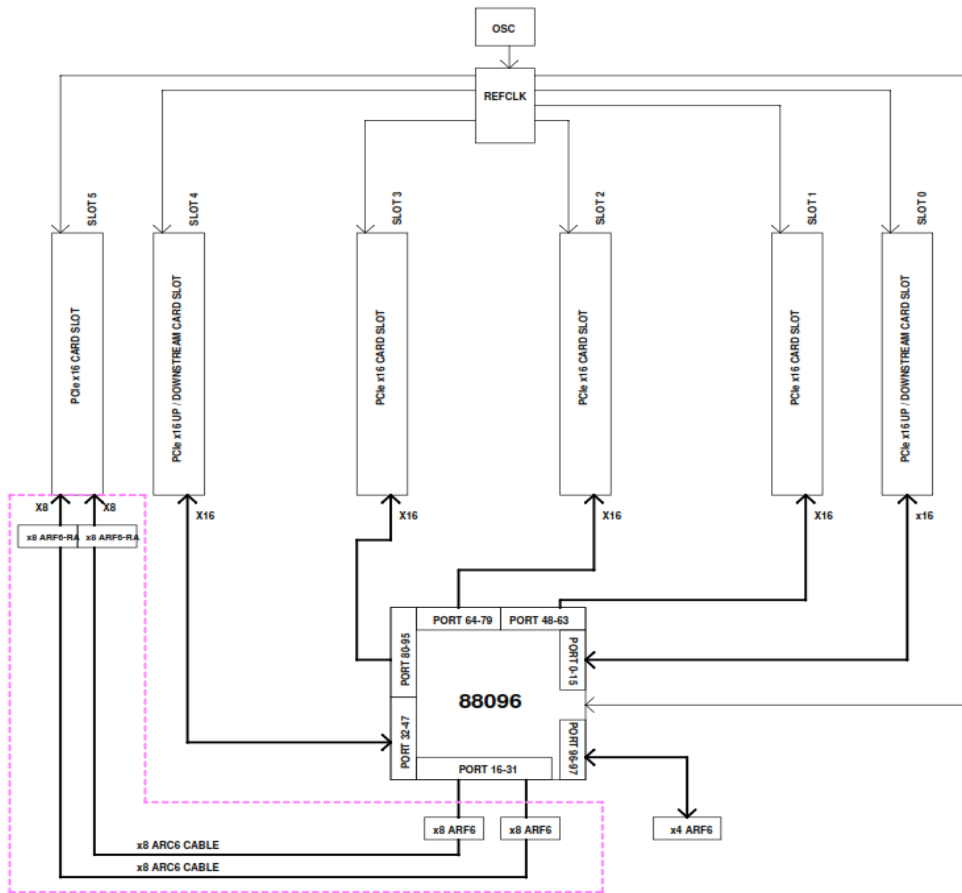

### 1.5 Dimensions

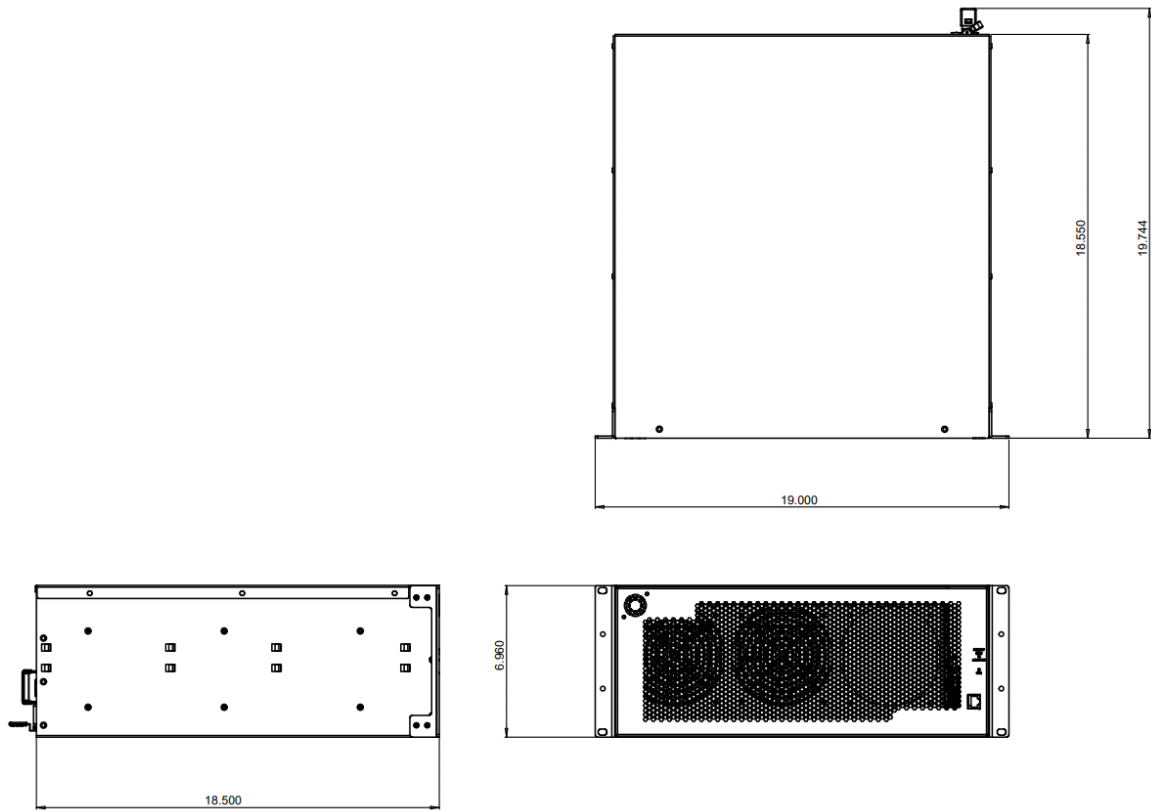

### 1.6 Parts Overview

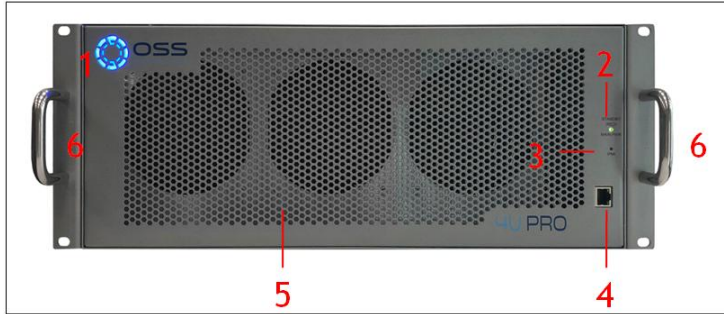

Number	Description
1	OSS LOGO-LED
2	Standby / Main Power LED
3	IPMI LED
4	RJ45 Port – Access to IPMI
5	Front Panel
6	Front Handles

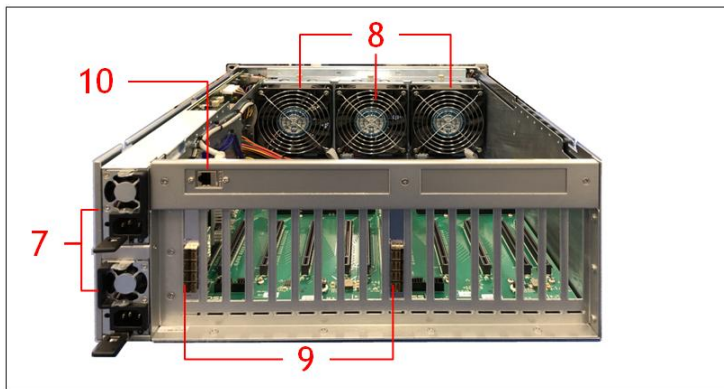

Number	Description
7	Power Supply Modules
8	Removable Fans
9	Target Cards
10	Rear RJ45 Port – Access to IPMI

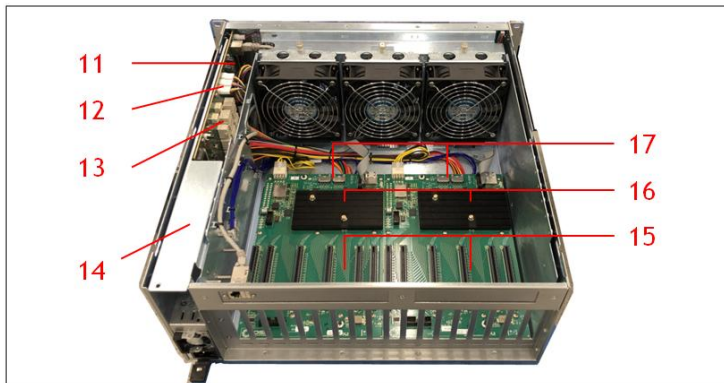

Number	Description
11	IPMI Module / Board
12	Fan Power Connectors
13	Auxiliary Power Connectors (10 qty)
14	Power Supply Housing
15	Backplane (OSS-538 board)
16	Passive Heat sink / PCIe Switch
17	ARF Connectors

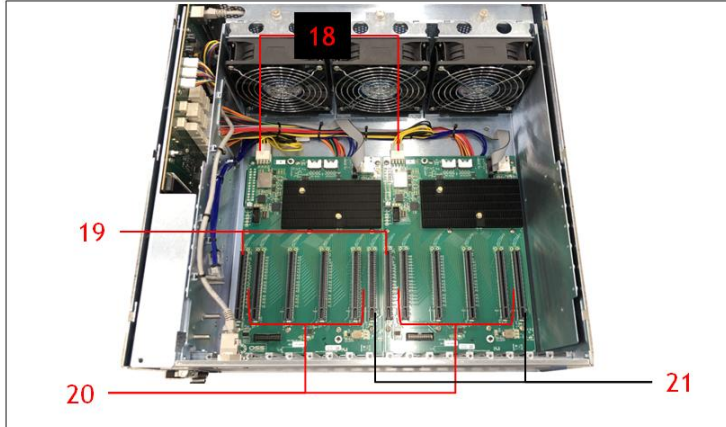

Number	Description
18	12V Input Power Connectors
19	Upstream Slots / Target Slots
20	Downstream Slot / PCIe Card Slots
21	Options Slots (Operates as either Downstream or Upstream depending on the configuration)

## 1.7 HIB x16 Gen 4 Card

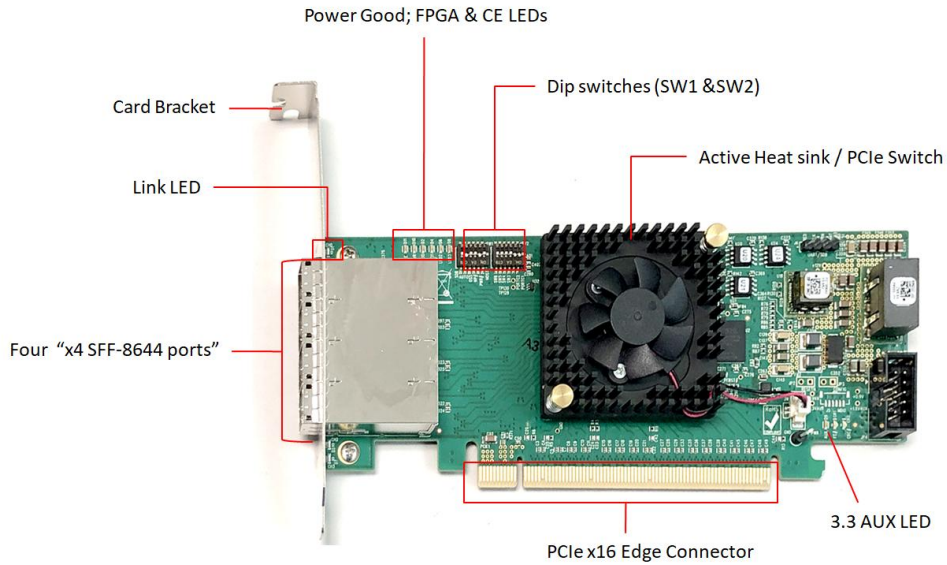

### x4 cable Ports

There are four x4 cable ports /connectors available on the HIB Gen4 card. **Port #0** is located nearest to the Link LED.

- A single x4 SFF-8644 cable must be inserted into port#0 of the Target card.
- On the Host card side, you can plug in a single x4 cable to any port as long as the Host card switch is set to x4 mode.

**When using two x4 SFF-8644 cables**, it must be connected to port#0 and port#1 of the Target card only.

- On the Host card side, plug-in the two cables to port#0 and port#1 **OR** port#2 and port#3.

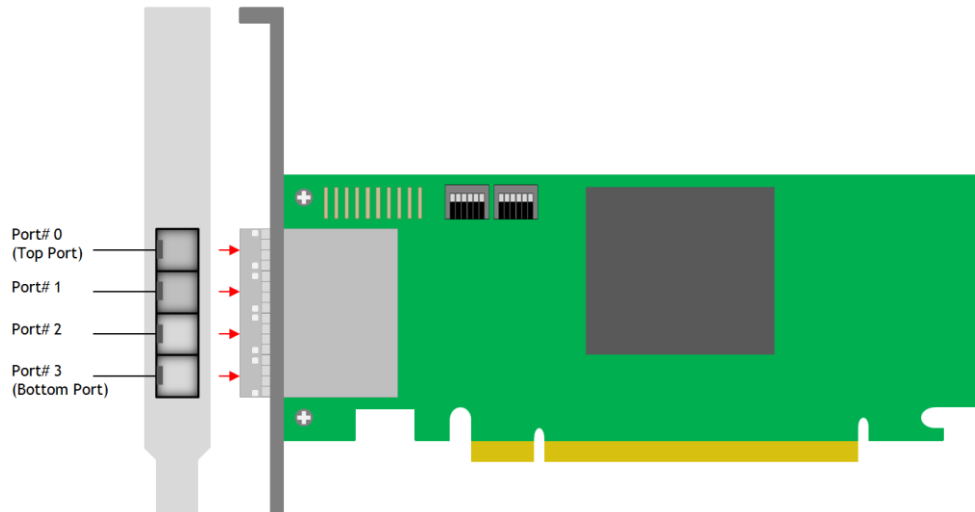

### 1.8 Backplane

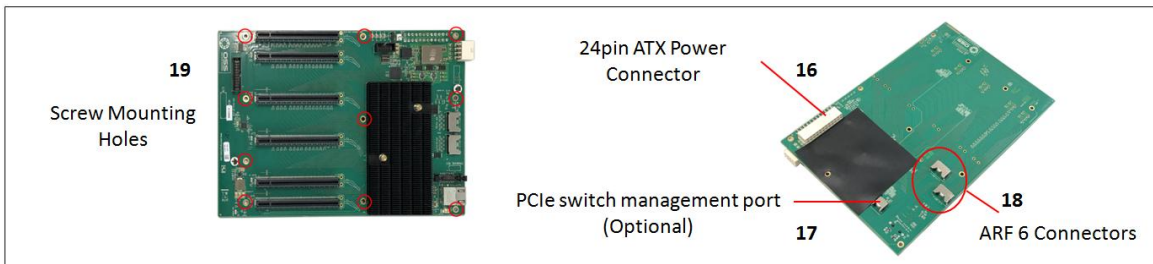
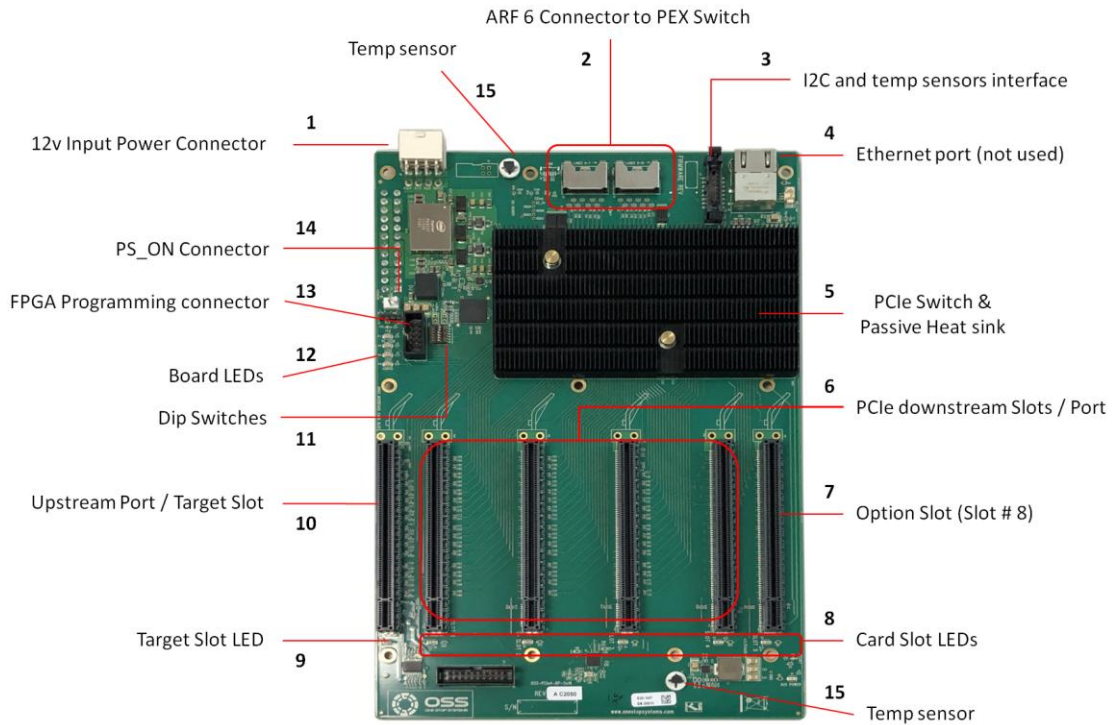

Item	Name	Description
1	12V Input Power	12V input power for the 538 board. Not to be used for external GPU aux.
2	ARF 6 Top Connectors	For connecting ARC 6 cables between "Option slot" and PEX switch
3	I2C and temp sensors interface	Connector for I2C and temp sensors interface to the power backplane
4	Ethernet port	Not used
5	Passive Heat sink	Moves <b>heat</b> away from the PCIe chip
6	PCIe Downstream Slots / Port	PCIe card slot for 3 <sup>rd</sup> Party PCIe cards
7	Option Slot	Configurable card slot to operate either as an Upstream or Downstream modes
8	Card Slot LED	LED status indicator when slot is populated or not. Solid green when card is present. Off, when no card.
9	Target Slot LED	LED status indicator for Target card. Solid green when Gen 4 adapter card is installed
10	Upstream Port / Target Slot	Designated slot for Target card only
11	Dip Switches	For slot configuration
12	Board LEDs	LED status indicator for the board
13	FPGA Connector	FPGA Programming connector
14	PS_ON	Enable to force power ON the backplane by placing a jumper on the connector
15	Temperature Sensor	Sensor for detecting temperature on the board
16	24-pin ATX Power Connector	For connecting ATX Power Supply
17	PCIe Switch Port	PCIe switch management port, optional
18	ARF 6 Bottom Connectors	For connecting ARC 6 cables between "Option slot" and PEX switch
19	Screw-Mounting Holes	For securing the board on to an enclosure

## 1.9 Slot Configurations

**Configuration# 1:** Default slot configuration. One Upstream slot and five Downstream slots.

You must have the ARC6 cables attached between the edge of the board and the slot connectors under the backplane. Without those ARC6 cables nothing will work in SLOT 5.

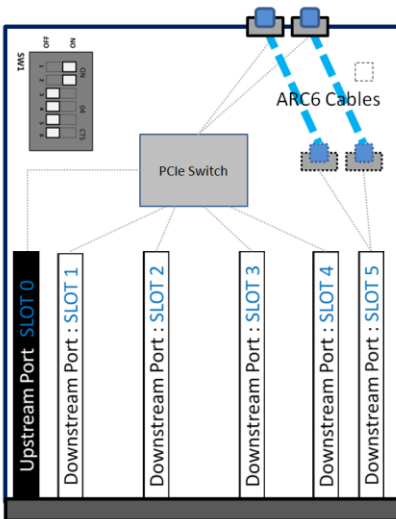

### 1 Upstream Slot (SLOT 0)

- One partition

### 5 Downstream Slots

- Slots # 1, 2, 3, 4 and 5

**Configuration# 2:** Two Upstream slots (Slot 0 and SLOT 5) with two partitions.

- Slot 0: Partition #1 with two Downstream slots
- Slot 5: Partition #2 with two Downstream slots

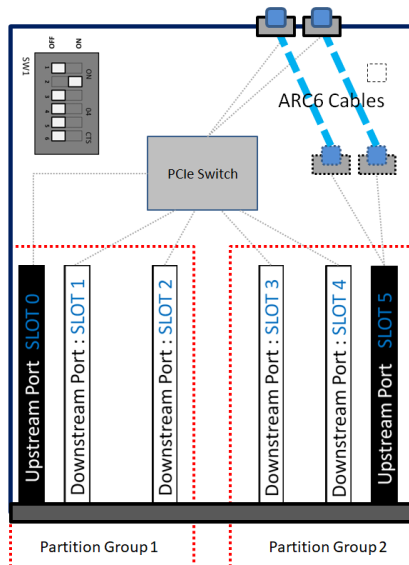

### 2 Upstream Slots (SLOT 0 and SLOT 5)

- Two partitions

### 4 Downstream Slots

- 2 Downstream slots for **partition group 1**

- Slots # 1 and 2

- 2 Downstream slots for **partition group 2**

- Slots # 3 and 4

**Configuration# 3:** Two backplanes are daisy chained together

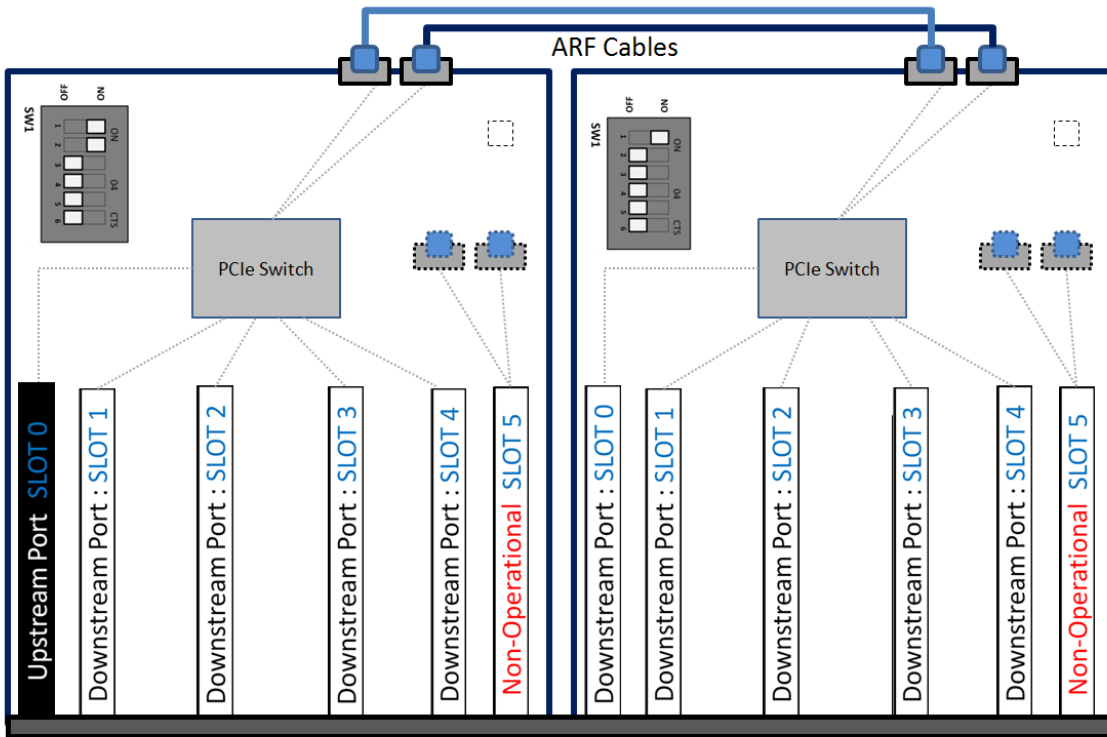

- 1 Upstream Slot
- 9 Downstream slots
- 2 Non-operational slots

### 1.10 Use Case Diagrams

#### Configuration 1

OSS-538 backplane is linked to a single host computer.

- Four x4 link cables are connected between OSS Gen4 Host card and Target card.

5 Downstream slots

- 5 x16 slots (Slot 1, 2, 3, 4 and 5)

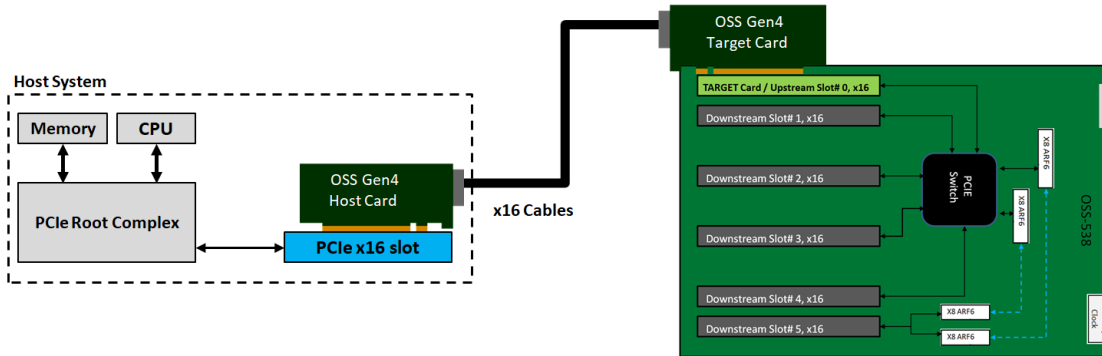

#### Configuration 2

OSS-538 backplane is linked to two host computers, see diagram below.

Two partitions / two Upstream slots (Slot 0 and SLOT 8) with a total of 4 downstream slots.

- Slot 0: Partition #1 with two Downstream slots
  - 2 x16 slots (Slot 1 and 2)
- Slot 8: Partition #2 with two Downstream slots
  - 2 x16 slots (Slot 3 and 4)

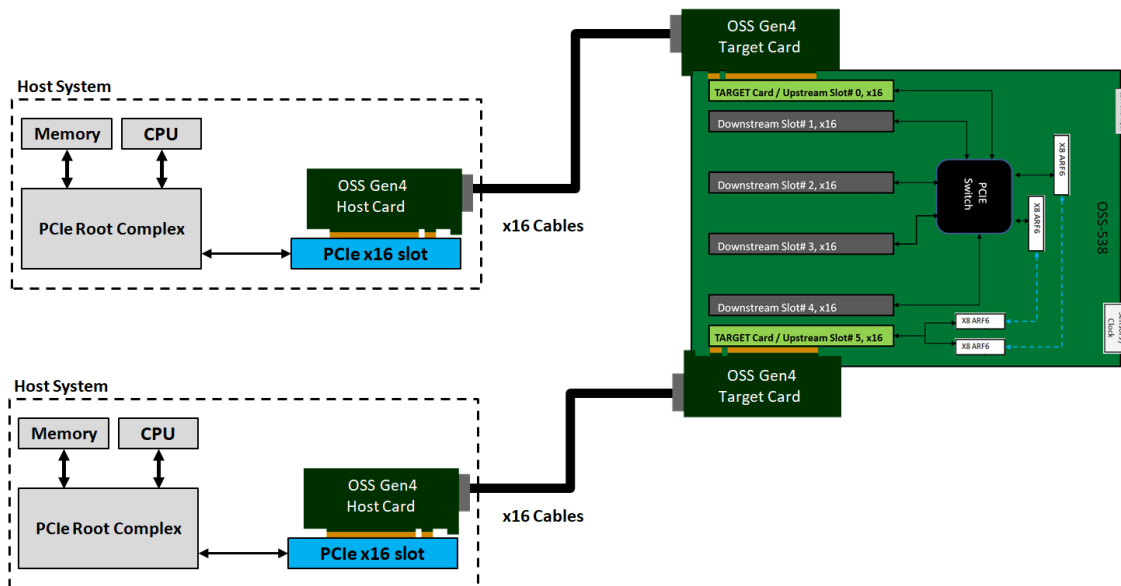

**Configuration 3**

Two OSS-538 backplanes are daisy chained together and it is linked to a single host computer.

- 9 Downstream slots

**1st backplane:** 4 downstream slots

- 4 x16 slots (slot 1, 2, 3 and 4)
- 1 non-operational slot (slot 5)

**2nd backplane:** 5 downstream slots

- 5 x16 slots (slot 1, 2, 3, 4 and 5)
- 1 non-operational slot (slot 5)

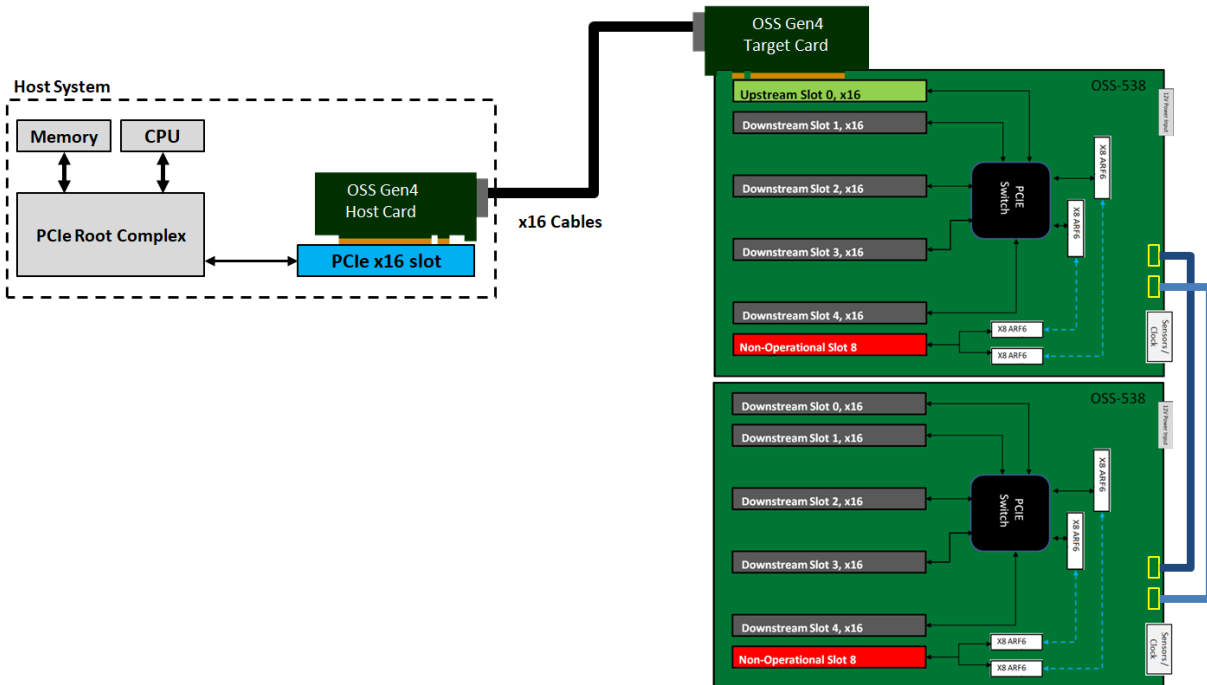

## 2 Getting Started

Steps on how to setup and use the 4UP expansion unit. You will find instructions for the following procedures:

- How to Remove Top Cover
- Target Card Installation
- Host Card Installation
- GPU / PCIe Cards Installation
- Mini-SAS Cable Installation
- Powering Up the unit / system
- Hardware LED Check
- Device Verification via OS

## 3 Installation Overview

1. Remove the top cover.
  - a. Check inside the unit for loose components or damaged parts.
2. Check the Target card, make sure it is firmly installed and secured.
  - a. By default, the Target is already installed in the unit.
  - b. If the Target card is not installed or missing, please go to section on how to install the target card.
3. Install the Host card.
  - a. You should have another card that is configured as host card.
  - b. Check the dipswitches make sure it is set to host mode prior to installing the card.
4. Install PCIe / GPU cards.
  - a. Plug in your PCIe or GPU cards in the expansion unit.
5. Connect the external link cables.
  - a. Plug in the Mini-SAS HD SFF-8644 cables between Target and Host cards.
6. Plug in the power cords.
  - a. The unit is supplied power cord(s). You should have either one or two, depending on the number of power supplies installed in the unit.
  - b. The standard unit is assembled with an AC power supplies installed.
7. Power ON the host computer.
8. Check the hardware by verifying all LED status indicators.
  - a. Boards LED
  - b. Target & Host cards
  - c. Unit front power LED
  - d. Power supplies LED
9. Check the OSS devices via operating system, verifying all OSS devices are properly recognized.
  - a. For Windows, go to section on how to verify device on Windows OS
  - b. For Linux, go to section on how to verify device on Linux

## 4 Remove Top Cover

1. Remove the two (2) mounting screws on top of the chassis.
2. Slide the enclosure cover towards the back of the unit to disengage it from the guides until it clears the back, and then lift the cover off.

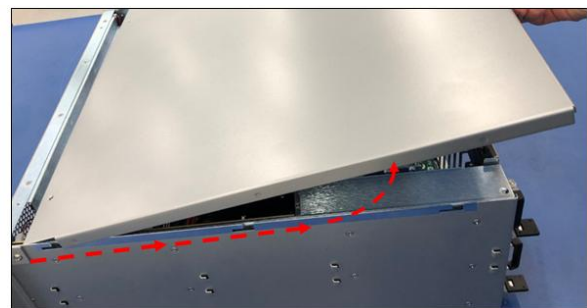
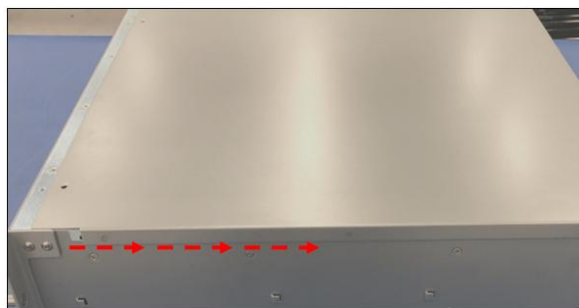
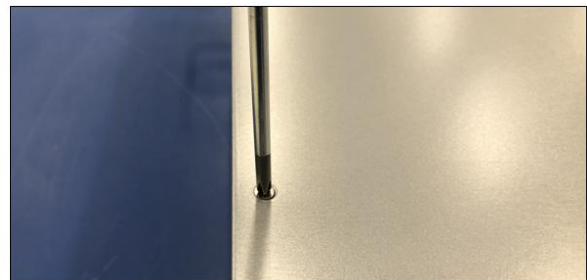
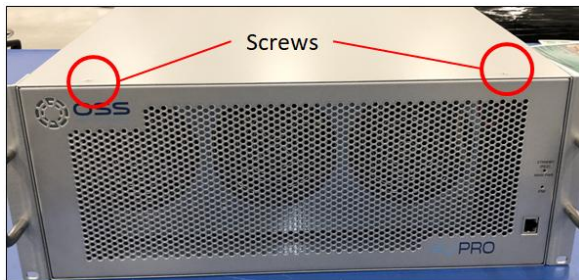

## 5 Target Card Installation

By default, the Target cards are already in the unit. See photos below for the correct slot location where the Target cards are installed.

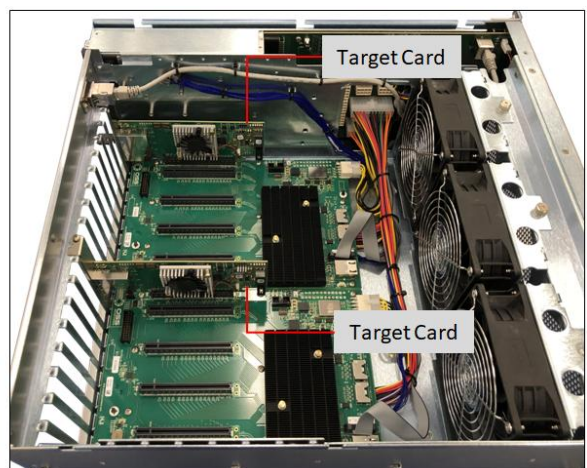
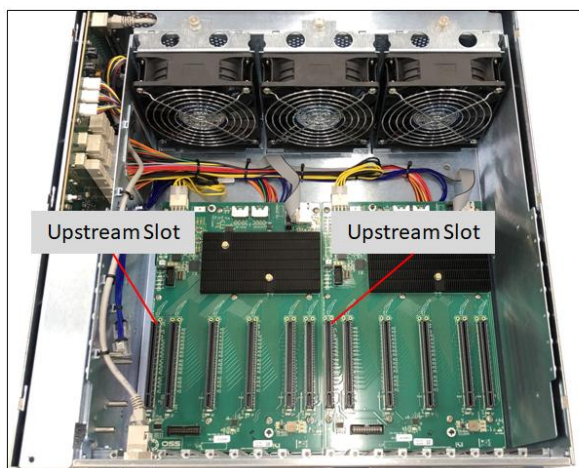

If the Target card is missing, follow the next steps below for Target card installation.

### 5.1 Target Card Configuration

- Configure the card first, make sure to set the card switches to Target mode.
- Find the SW1 on the card and set the switches to target mode, see diagram / photo below.
- Move SW1 #1 and SW2 to ON position

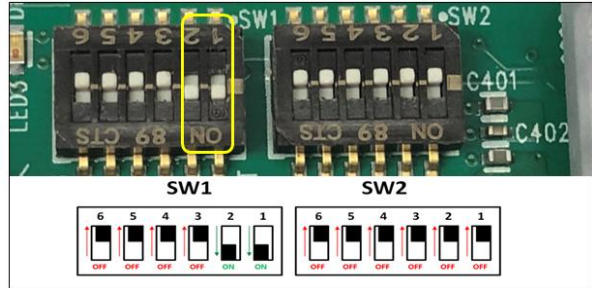
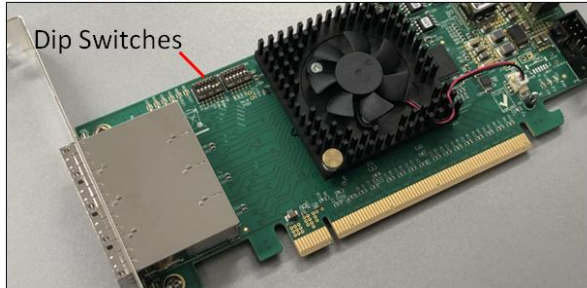

Once the card is configured, install the Target card in the designated target slot (upstream slot# 0). Photo below shows the exact location of the Upstream slot (Slot 0).

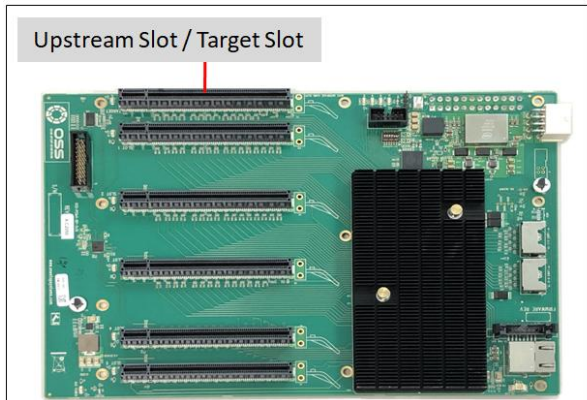

Make sure the card is firmly seated in the card slot and secured.

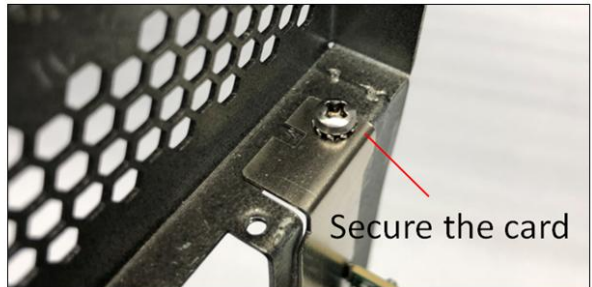

## 6 Host Card Installation

- Before installation, you must check the switches on the Host card.
- By default, all the switches on the Host card are set to OFF position (“Auto-Negotiation” mode).
- You can leave the switches to default or you can set the switches (SW1 and SW2) on the card for the desired Host operating mode. See “Host Card Configuration” section for more details.

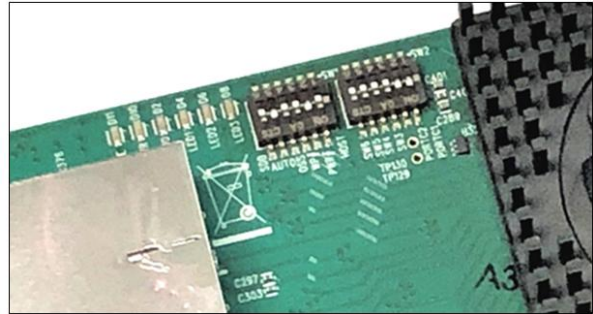
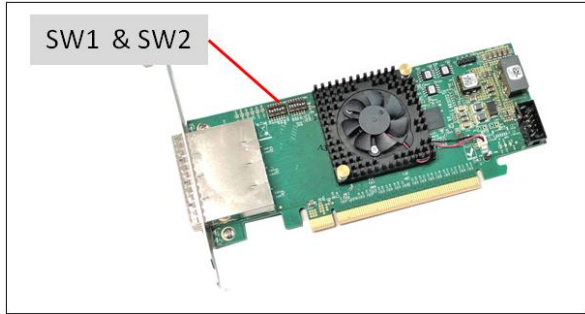

### 6.1 Host Card Configuration

The following diagrams / photos are the switch settings for the Host card.

#### x16 Dip switch Settings:

- SW1 #2 = ON; #5 = ON.
- SW2 #1 = ON; #2 = ON

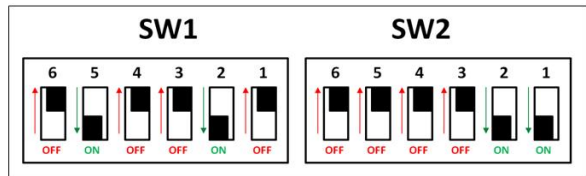
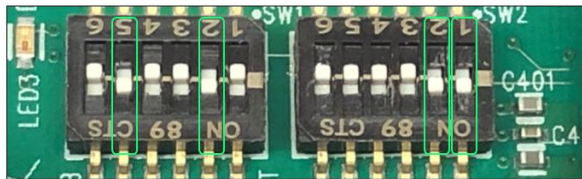

#### x8 Dip switch Settings:

- SW1 #2 = ON; #5 = ON
- SW2 #1 = OFF; #2 = ON or #2 = OFF and #1 = ON

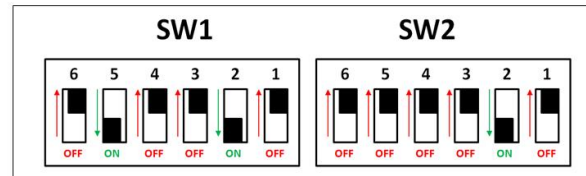
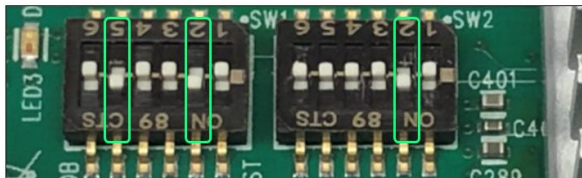

**x4 Dip switch Settings:**

- SW1 #2 = ON; #5 = ON
- SW2 = All OFF

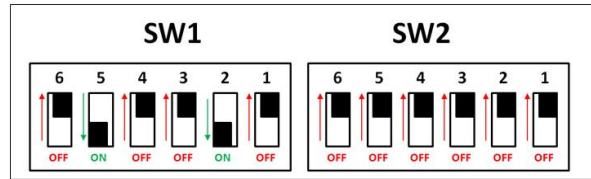
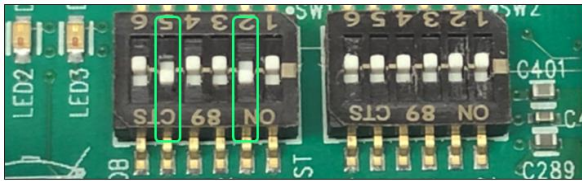

Once the Host-card is configured, install the card into a x16 Gen4 PCIe slot on a computer motherboard.

- Check the PCIe slot for any foreign debris as this can damage the card during installation.
- Align the host card edge connector on top of the PCIe slot and carefully push the card down until it is firmly seated.
- Secure the card with the screw.

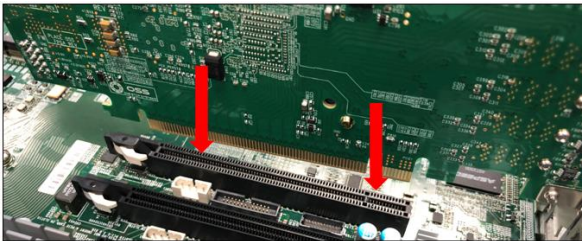

Below is a photo of a x16 PCIe slot connectors. The photo on the right is a PCI-E 3.0 x16 slot. The specification of the PCIe slot is printed on the board next to connector for easy identification. Use a x16 PCIe slot for the host card to achieve stable performance.

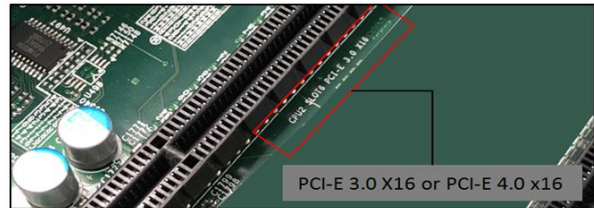

## 6.2 Dip switch Settings

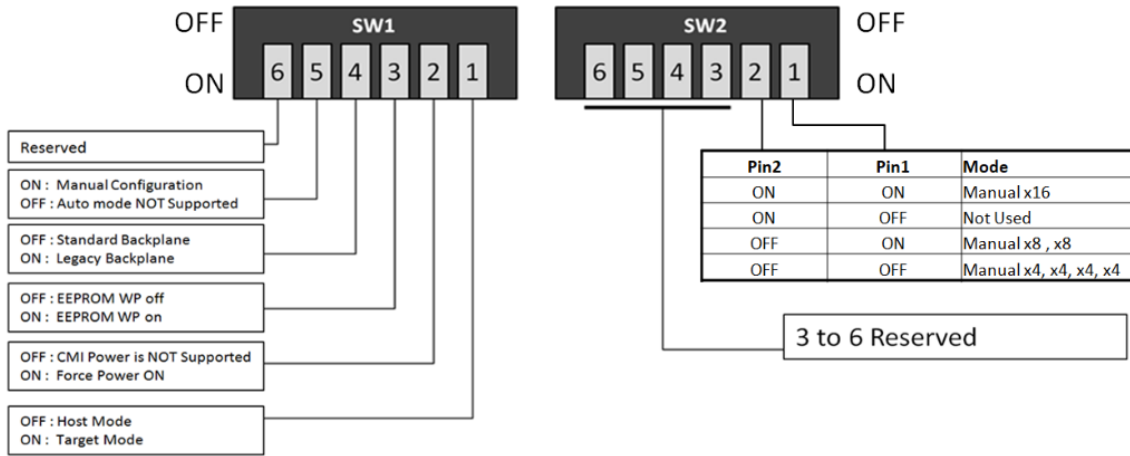

- SW1-5 must always be ON. Auto mode not supported
- SW2-3 to 6 are not used.
- Legacy backplane: Magma Gen3 backplane

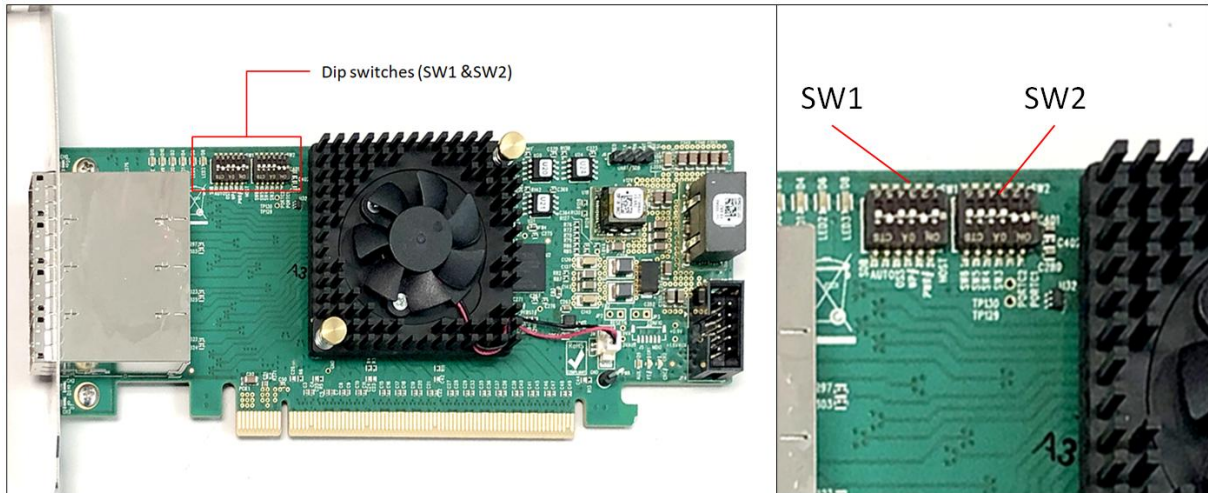

## 7 GPU / PCIe Cards Installation

This chapter provides information on how to install GPU cards or PCIe cards into your One Stop Systems expansion chassis. More details on the installation of individual cards are provided by the card's manufacturer.

Install or plug your PCIe cards in the downstream PCIe slot. There are 5 available slots and one Upstream slot.

- **Slot 0** is the Upstream slot (aka: Target Slot)
- **Slots 1, 2, 3 and 4** are downstream slots.
- **Slot 5** is an option slot. Configurable to upstream or downstream modes.
  - Downstream mode: Use downstream slot for an end-point device (i.e. video card, Ethernet, sound card and etc).
  - Upstream mode: Use upstream slot for an OSS Gen4 target card only.

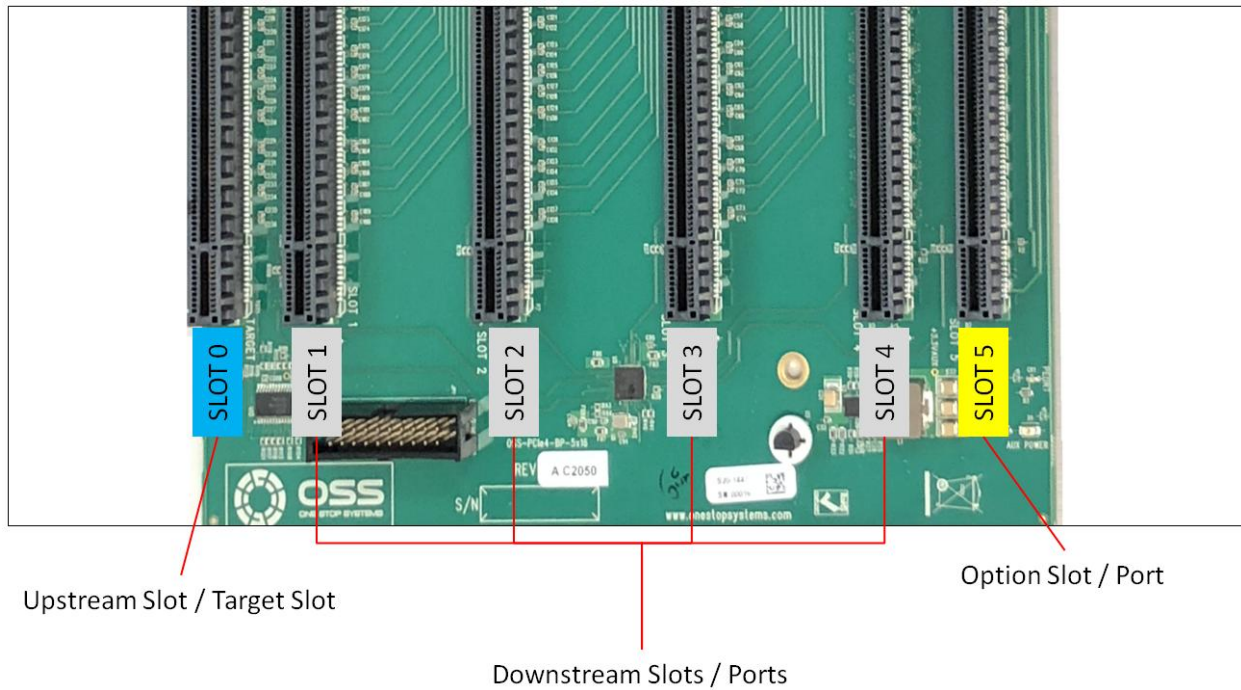

**IMPORTANT:** You need the ARC6 cables attached between the edge of the board and the slot connectors under the backplane. Without those cables nothing will work in slot 5. For more information on the option slot configuration, you can download the installation guide from the OSS support website.

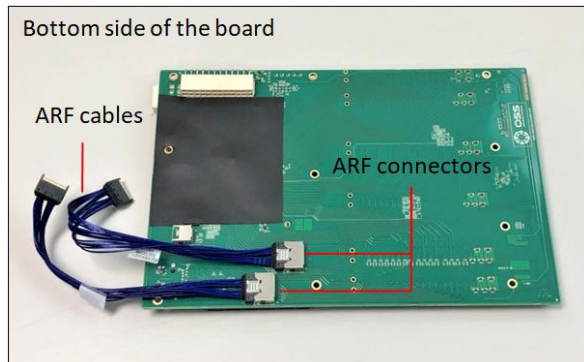

4U Pro 10 Slot

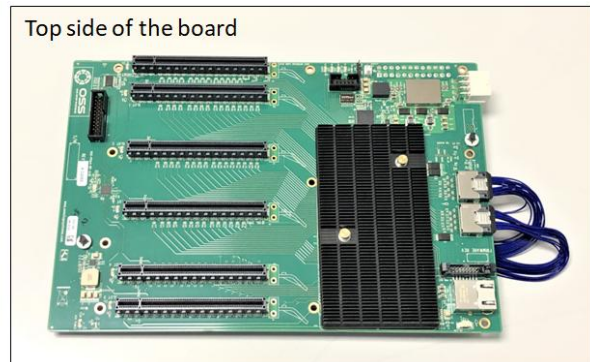

23

## 7.1 Install PCIe card / GPUs

In this example we are using NVIDIA A100 GPU.

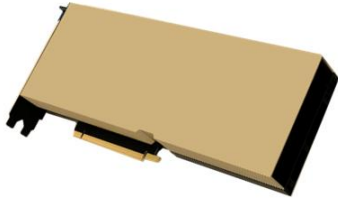

NOTE: Be sure to install the GPU cards following the card manufacturer's recommendations. Some GPU card manufacturers recommend that you install their software driver(s) prior to installing the hardware.

- Install GPU card in the downstream slot one at a time.
- Align the card on top of the slot.
- Gently push the card down until it is firmly seated.
- Secure the GPU or the PCIe cards.

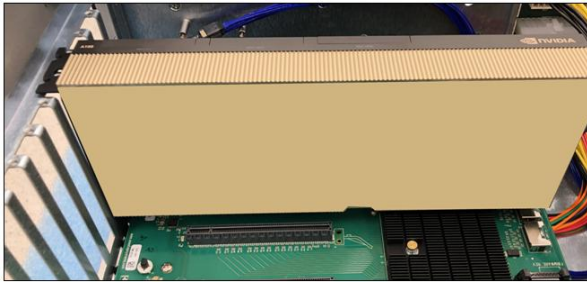

## 7.2 Connect Aux Power Cables

Plug in the appropriate auxiliary power cable to each GPU. Use the supplied compatible aux cable for your GPU. Photos below is an example of an auxiliary power cable available from OSS for purchase.

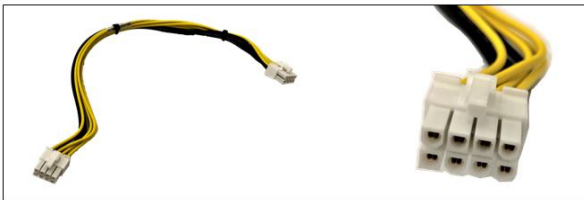

Plug in the aux cable to the GPU.



Plug in the other end of the aux cable to any of the available auxiliary power connectors on the power distribution board.

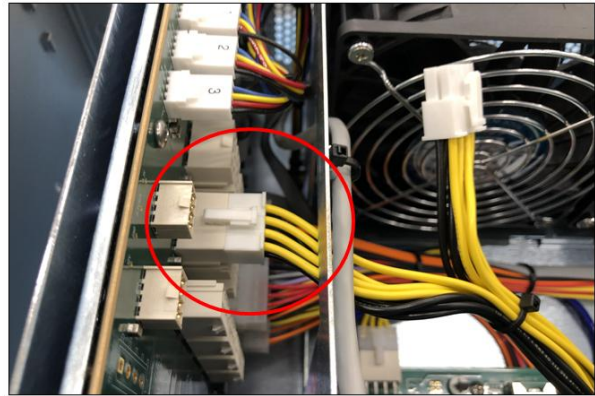
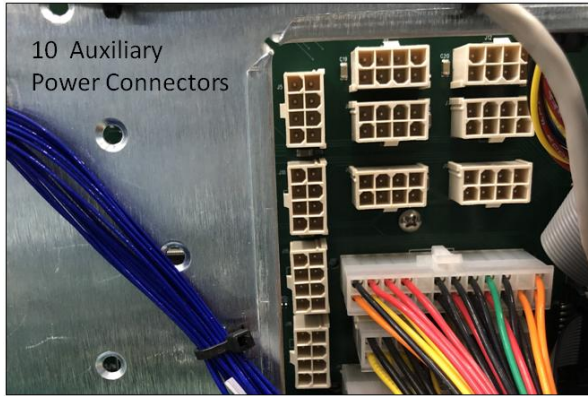

Perform the same installation methods for the remaining GPUs.



### 7.3 Auxiliary Cable Management

Route the cables away from the fan. Make sure the cables are not blocking the air flow. Use a zip-ties or tie-wraps to tuck the cables in. You can also use a Velcro strap to hold or tie down the cables.



## 8 Connect Link Cables

Use Gen4 Cables



### 8.1 Mini-SAS HD SFF-8644 Cable Installation

Connect all the appropriate PCIe link cables needed for the system.

- When the host card is configured to operate at x16 mode, connect all four link cables.
- Configured to operate at x8 mode, connect two link cables.
- Configured to operate at x4 mode, connect one link cable.

See the following cable configurations for more details.

#### 8.1.1 x16 Configuration: FOUR cables

- Plug-in the 1<sup>st</sup> cable to Port#0 (Top port) on both Target and Host cards.
- Plug-in the 2<sup>nd</sup> cable to Port#1 on both Target and Host cards.
- Plug-in the 3<sup>rd</sup> cable to Port#2 on both Target and Host cards.
- Plug-in the 4<sup>th</sup> cable to Port#3 (Bottom port) on both Target and Host cards

Note: It is easier to plug in the cables starting from bottom to top.

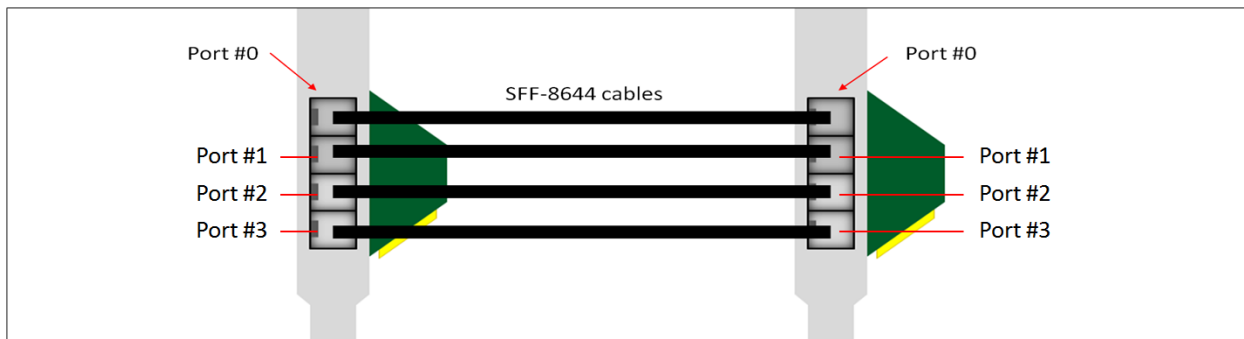
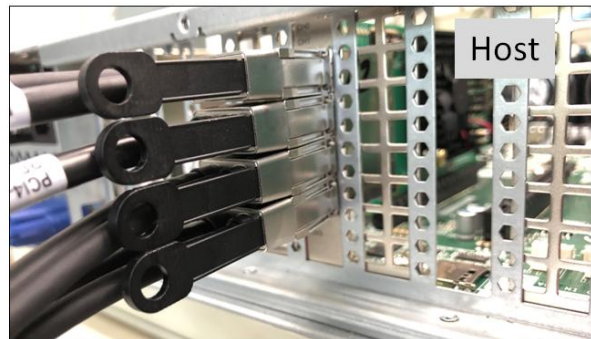

### 8.1.2 x8 Configuration: TWO cables

Note: Make sure the HIB616-x16 host card is manually set to x8 configuration, see the x8 switch setting section for more details

- Plug-in the 1<sup>st</sup> cable to Port#0 (Top port) on both Target and Host cards.
- Plug-in the 2<sup>nd</sup> cable to Port#1 on both Target and Host cards..

On the host card side, you can also use the two bottom ports (PORTS # 2 & # 3)

- 1<sup>st</sup> Cable to PORT #2
- 2<sup>nd</sup> cable to PORT #3

Note: The two cables on the TARGET card must remain connected on PORT #0 and PORT #1. See diagrams below as an example.

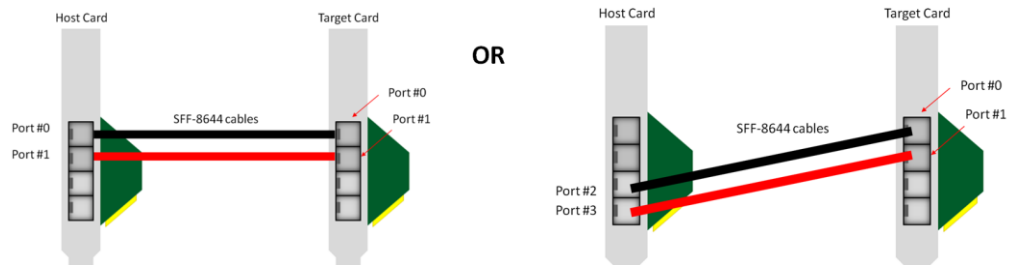

**Photo B1:** The two cables are connected on the Target card PORTS # 0 and # 1. The other end of the cables are connected on the Host card PORTS # 2 and # 3.

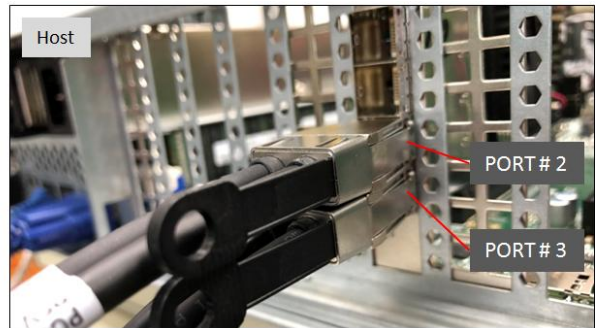
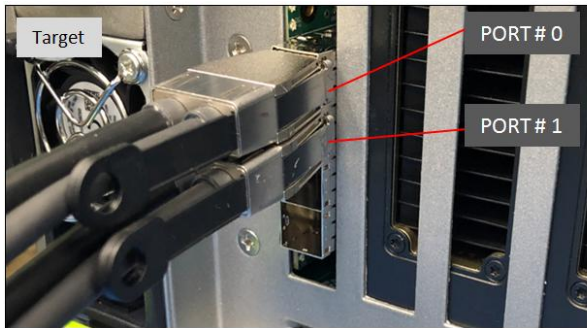

**Photo B2:** The two cables are connected on the Target card PORTS # 0 and # 1. The other end of the cables are connected on the Host card PORTS # 0 and # 1.

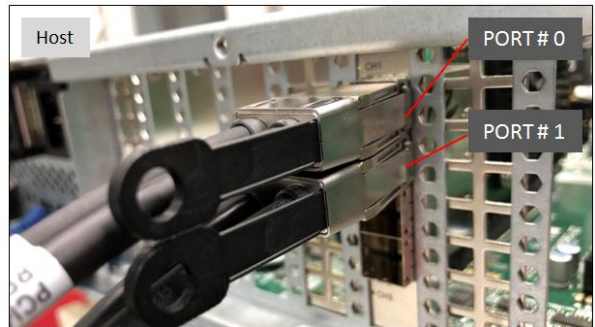
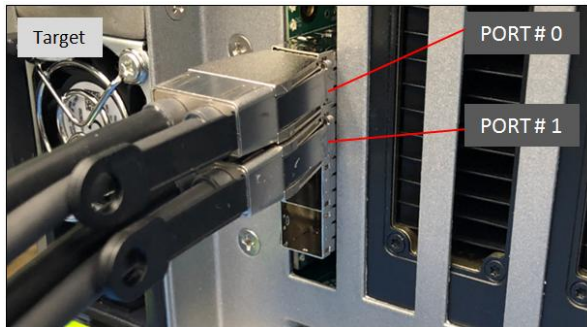

### 8.1.3 x4 Configuration: ONE cable

- Plug-in the single cable to Port # 0 (Top port) on both Target and Host cards



You can move the x4 cable on the HOST card to any available port. The other end of the cable stays connected on Target card PORT # 0.

**Photo A1:** Cable is connected on the Target card PORT # 0. The other end of the cable is connected on the Host card PORT # 1



**Photo B1:** Cable is connected on the Target card PORT # 0. The other end of the cable is connected on the Host card PORT # 2.



**Photo C1:** Cable stays connected on the Target card PORT # 0. The other end of the cable is connected on the Host card PORT # 3.



Diagrams below are different x4 cable configurations.

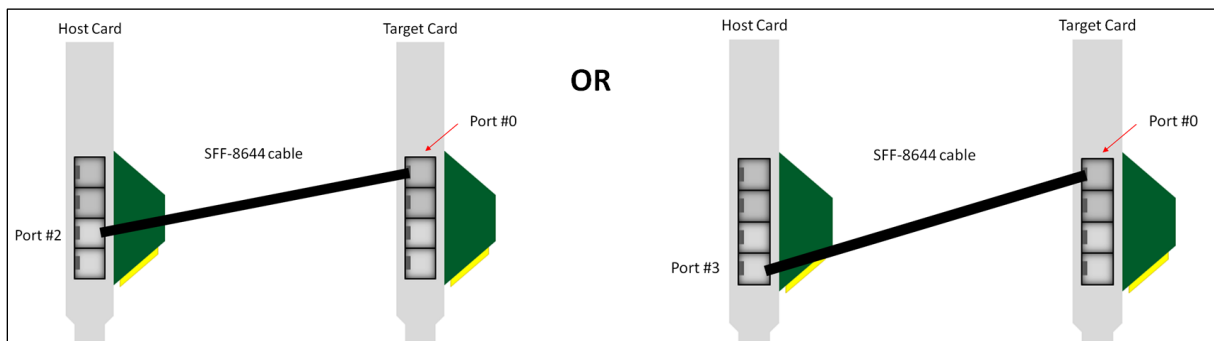
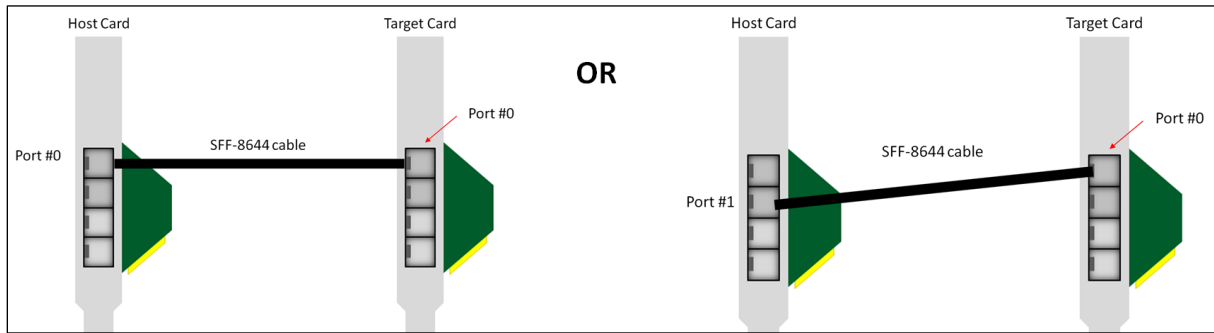

## 8.2 Disconnecting Mini-SAS HD SFF-8644 Cable

To disconnect the link cable, pull back the PLASTIC thumb tab to release metal clamp while slowly pulling the cable out.

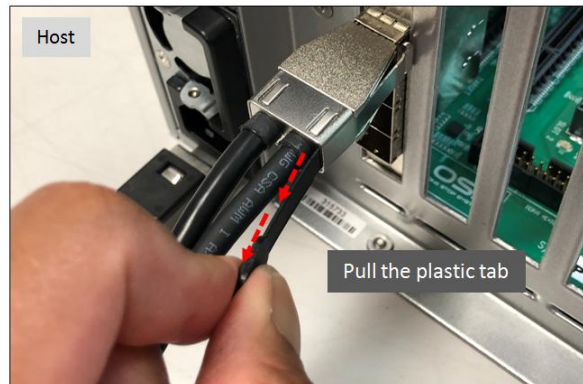

## 9 Applying Power Correctly

### 9.1 Connecting to electrical outlet

It is highly recommended using a power surge to protect your gear against random power spike damage. This product is provided with a power supply that **automatically adjusts to input voltages between 100 to 240 Vac**. A U.S. and Canadian 125V or 250V power supply cord is provided with this product. If you are using a 250V power cord, you would need to connect that to a PDU (power distribution unit). You can buy the PDU on any online electronic stores. OSS does not sell the PDU.

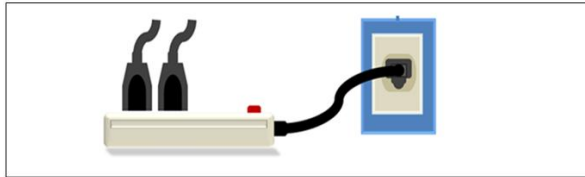

### 9.2 Connect Power Cords

Use the power cord supplied with the unit, connect the power cord to the back of the power supply. Ensure that the system's power supply unit is fully secured before connecting the power cord. You should have either the 125v or the 250v power cord. If you only have the 125V power cord and you require the 250V power cord please contact our Sales Team ([sales@onestopsystems.com](mailto:sales@onestopsystems.com)) to place an order.

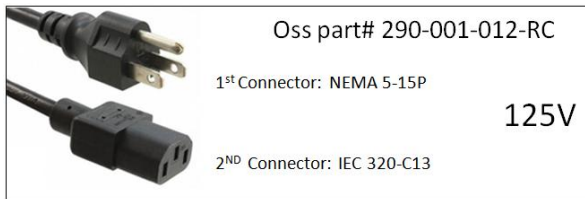

#### Power Cord Voltage Table

Power Cord	PSU Watt	Voltage	AMPS	Hz
125V	1000W	100-127V	12-9.5A	50-60Hz
250V	1800W	200-220V	10-9.5A	50-60Hz
250V	1980W	220-230v	10-9.8A	50-60Hz
250V	2000W	230-240V	10-9.8A	50-60Hz

When using 115-125V power cord, the output power is limited (1000W)

Plug in the power cords to the power supplies, the entire unit will power UP.

- Power Supplies are ON
- All fans are activated
- Backplanes are ON

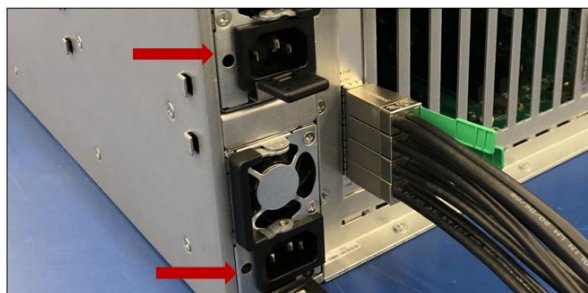

4U Pro 10 Slot

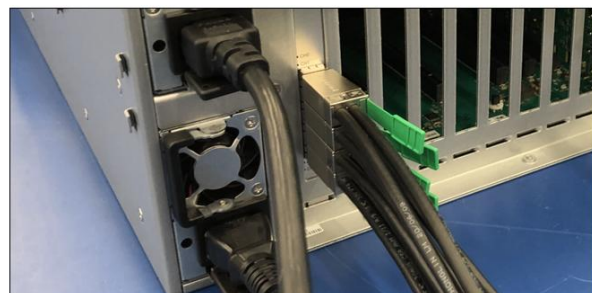

Green LED: PSU Good

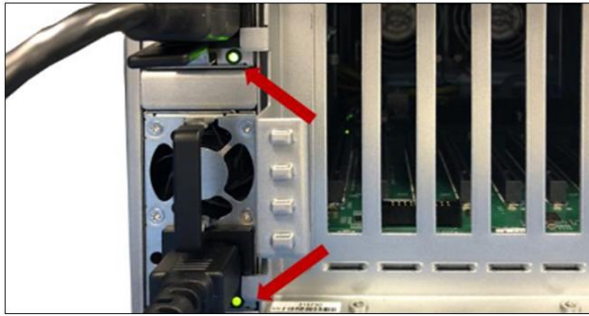

Amber LED: PSU fault or power issue. If Power LED indicator is showing "Amber" in color, it indicates a fault or power issue.



The two front LEDs, the OSS logo will illuminate as blue and the "STANDBY"(MAIN PWR) will come ON as "solid-green".

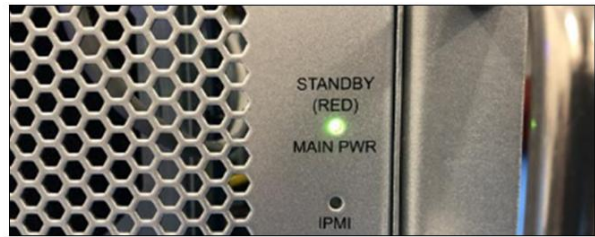

## 10 Powering UP the Computer

Before powering UP or turning ON the Host computer, make sure the Host adapter card is seated properly in a x16 Gen3 / Gen4 PCIe slot and the cables are firmly connected. Upon powering up the Host computer, it will initialize a link between the target and the host. The Link LED on both target and host cards will illuminate as solid green.

- Solid green Link LED, it means the negotiated link width between host and target card is x16.
- Blinking green Link LED, the link width is x8

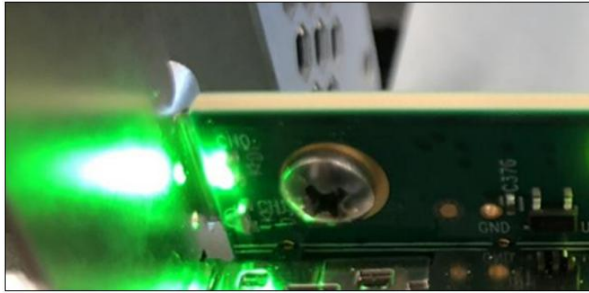

## 11 Hardware Check

### 11.1 Verify Board LEDs

Check the Target SLOT LED, when a PCIe card is installed in the target slot, the LED will illuminate as solid green.



A fully operational back plane will illuminate the following LEDs. Check LEDs D9, D8 and D1, make sure they are correctly illuminated.

- D9- Blinking green (LED 1).
- D8-Solid green(LED 0).
- D1- AUX power, solid green.

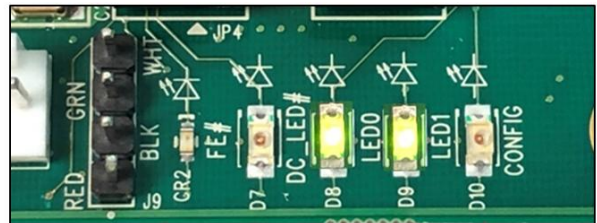
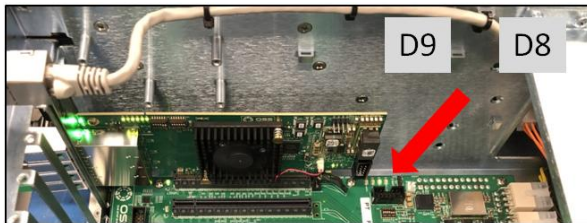

## 11.2 Fault LEDs (RED)

When the RED LED is lit on the backplane it signifies fault or error.

CR2 / FE (Fatal Error) LED  
 Solid RED: Something wrong with the board

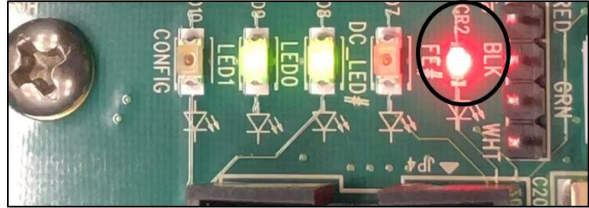

D10 / CONFIG LED  
 Solid RED  
 • The backplane is not programmed  
 • Or the FW image is corrupted

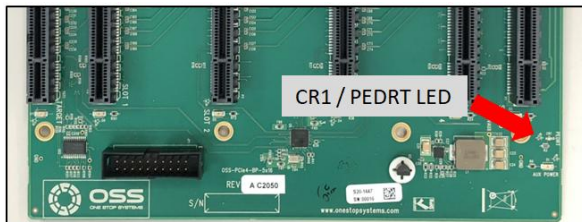
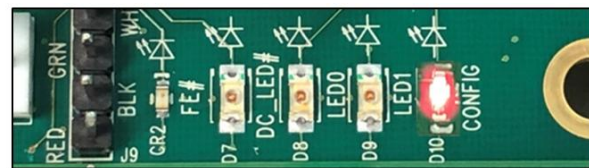

RED LED (CR1 / PEDRT):  
 The backplane is not getting initialized due to  
 \* Faulty Target card  
 \* Board is not programmed

### 11.3 Verify Adapter Card LEDs

A working HIB adapter cards will illuminate the following LEDs (on both Host and Target cards).

D11	CE( Card edge)	Solid green
D10	PWR (Power)	Blinking green
D2	LED 0	Solid green
D4	LED1	Solid green
D6	LED2	Solid green
D8	LED3	Solid green
CHO	Link LED	Solid green
D9	Aux Power	Solid green

#### x16 configuration (Four x4 Cables connected)

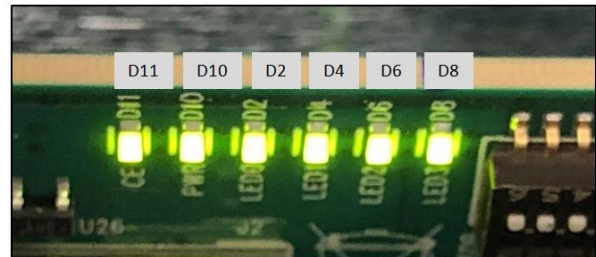
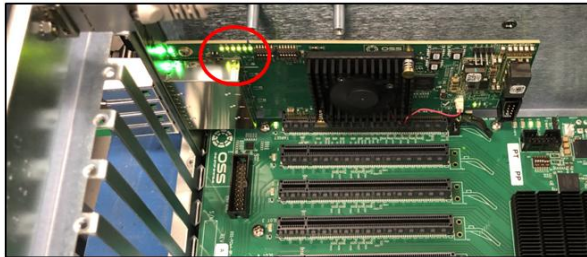

CHO LED will illuminate as solid green, indicates of a stable LINK between Target and Host cards.



When there is no link between Target and Host cards, the CHO LED is turned OFF.



The C9-Aux power LED will illuminate as solid green, which is an indication of power is present on the card.

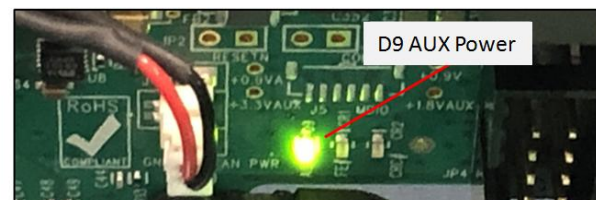

### 11.4 Adapter Card LED Definitions

LED		Status	Description
CH0	D1	ON (Solid Green)	Link LED. Indicates a connectivity between OSS Host and Target cards.
LED0	D2	ON (Solid Green)	Power Good
LED1	D4	ON (Solid Green)	Power Good
LED2	D6	ON (Solid Green)	Power Good
LED3	D8	ON (Solid Green)	Power Good
CE	D11	<b>ON (Solid Green)</b>	Solid Green: The CARD EDGE connector is communicating to Gen4 PCIe switch on the host computer motherboard.
			Blinking Green: The CARD EDGE connector is communicating to Gen3 PCIe switch on the expansion board / backplane
PWR	D10	ON (Blinking Green)	Power Good / FPGA Healthy
AUX	D9	ON (Solid Green)	AUX Power Good

LEDs for SFF-8644 Cable Link cases:

1. Target mode (x16): D1 is the link indicator
2. Host Mode, x16: D1 is the link indicator
3. Host Mode, x8x8: D1 or D5 are the link indicators (one for each corresponding group of two SFF cages)
4. Host Mode, x4x4x4x4: D1, D3, D5, D7 are the link indicators (one for each SFF cage)

### 11.5 Slot LEDs

- The SLOT LEDs will illuminate either Solid green or blinking if a PCIe card is occupying the slot.
- The Target SLOT LED will illuminate as solid green.

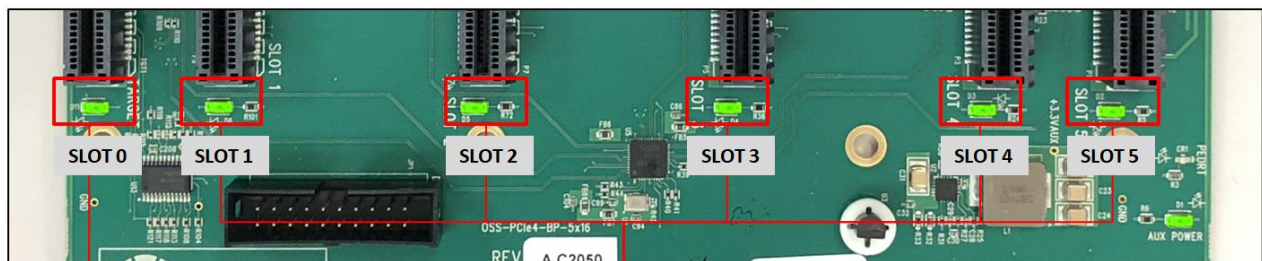

Target Slot LED

PCIe card slot LEDs

Solid	Gen4 Link
Blink 2Hz	Gen3 Link
Blink 1Hz	Gen2 Link
Blink 0.5Hz	Gen1 Link (Slow Blinking)
OFF	No card installed

### 11.6 Power Distribution Board LED

- When the PSU DC GOOD led is not illuminated, it is an indication of a faulty power supply and the unit will not power ON.
- Solid green- the PSU is working properly.

See photos below for the location of the “PSU DC GOOD” led.

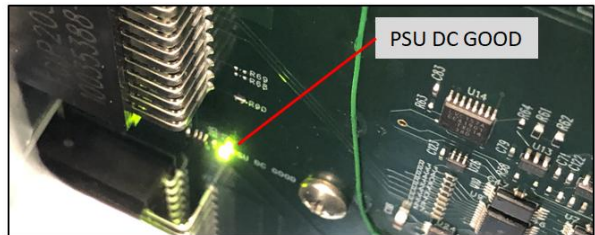
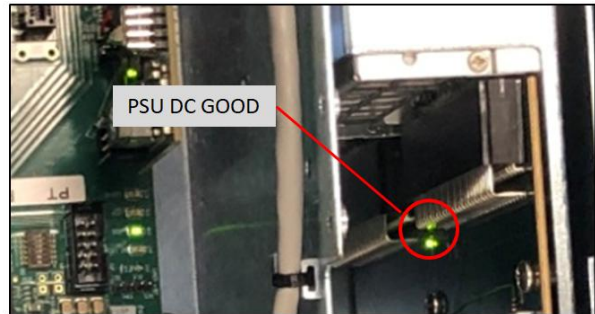
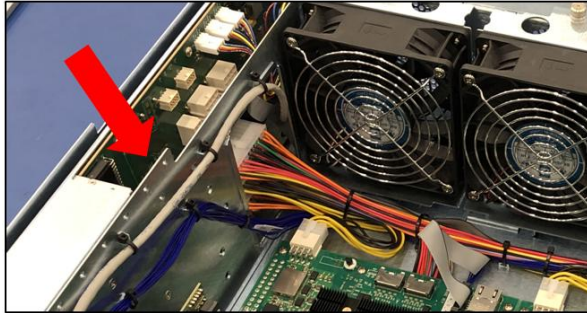

### 11.7 Front LED

There are three visible LEDs located on the front of the unit.

- The LOGO led, will illuminate as solid BLUE.
- Standby / MAIN PWR—Solid green when unit is fully powered ON. Red when the unit is on standby mode.
- IPMI – This is optional. Will only illuminate as solid green when IPMI module is installed in the unit.

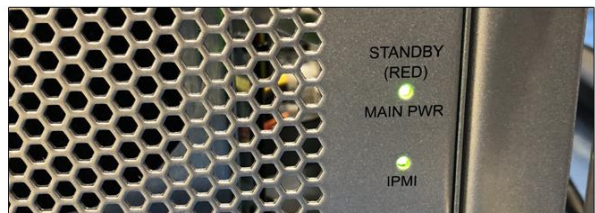

## 11.8 Power Supply LED Indicator

Both LEDs on the Power Supply should be ON as solid green, it indicates the OK status of the DC GOOD signal. The LED shall continue to glow under normal operation of the power supply.

During protection mode (main 12V rail), the LED should be amber.

- During protection mode (5Vsb rail), the LED should be OFF
- When protection is cleared, the LED should go back to the original intended status.
- When the unit is on standby with AC is present, the LED should be amber.
- When the unit is on standby with no AC is present, the LED should be OFF.
- When the unit is turned ON properly, the LED is green.
- During wakeup redundancy mode, the LED should be green.
- During wakeup redundancy sleep mode, the LED should be blinking green in 1Hz.

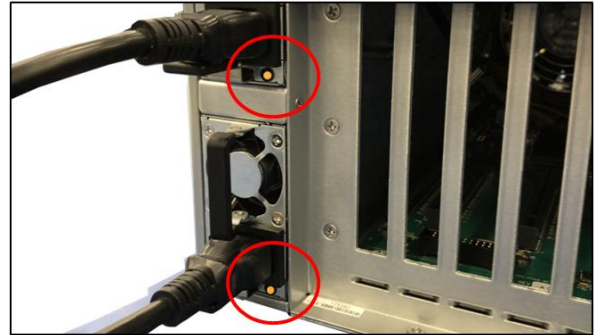
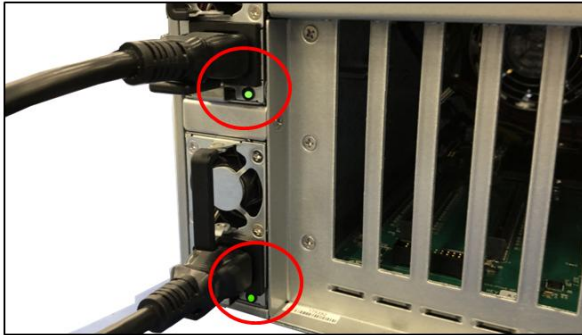

## 12 Software Installation

### 12.1 Software Driver Installation

One Stop Systems 4UP expansion unit requires no driver on Windows 7, Windows 8, Windows 10, Windows Server, Linux, Unix, Centos and Mac OS.

Before attempting to install anything on a Windows system, you should ensure that you have set a Restore Point, that all data files are closed and that you have a current backup of your data.



## 13.2 Windows 10 / Server

On Windows, find the 'My Computer' icon and "right-click" on it.

- Then select 'Manage' from the pop-up menu.
- Next, click on 'Device Manager' in the leftmost Computer Management window.
- Finally, click on the View Menu and select View Devices by Connection.

When everything is functioning correctly, your Windows Device Manager should look something like the screenshot below.

You will see multiple PCI standard PCI-to PCI bridge or PCI Express standard Upstream Switch Ports and PCI Express standard Downstream Switch Ports.

### 13.2.1 HIB Cards and Backplane

#### Viewing devices by connection

- Displaying a link between Host and Target cards.
- OSS backplane / board with **no** PCIe cards installed—the downstream slots on the backplane are not populated.
- Showing multiple layers of PCI Express standard Upstream Switch Port and PCI Express standard Downstream Switch Port.

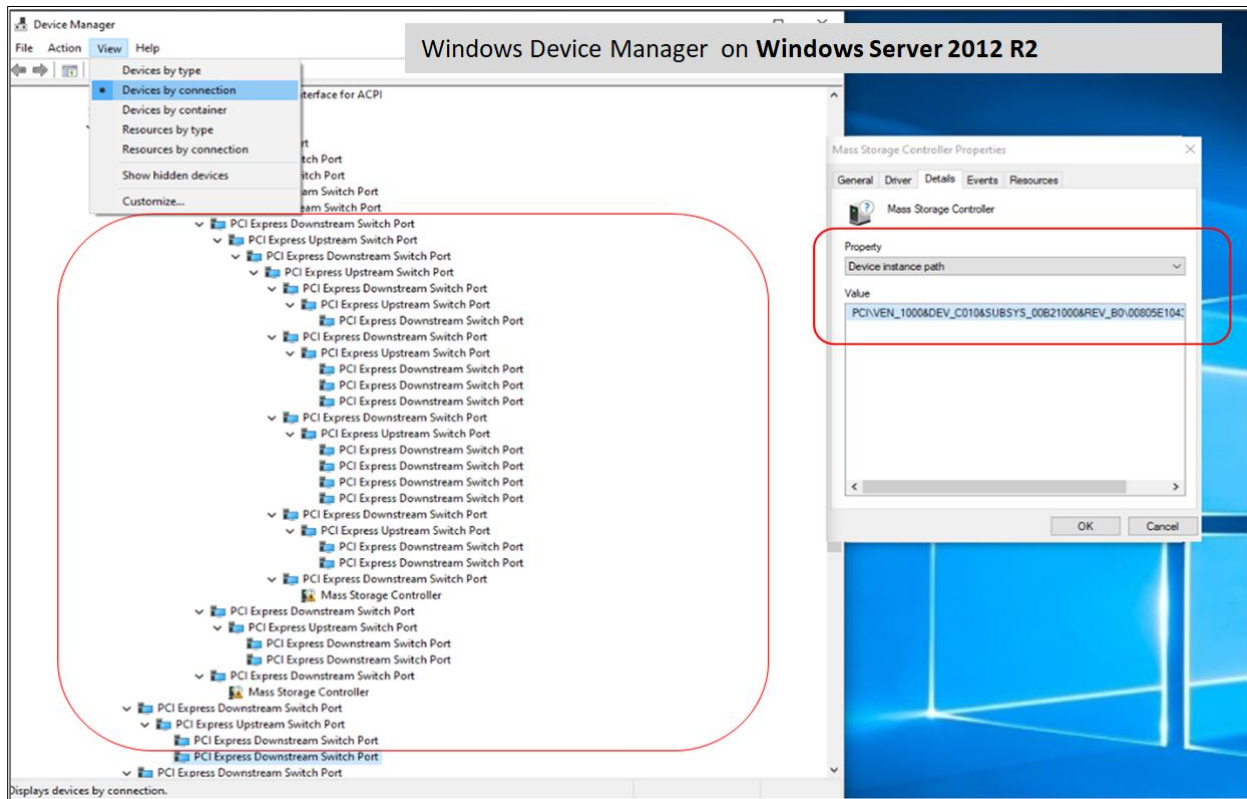

### Viewing devices by type

Both adapter cards (host and target cards) and backplane are recognized / detected.  
The devices are coming up with a Yellow Exclamation point, this is normal. No need to install any drivers.

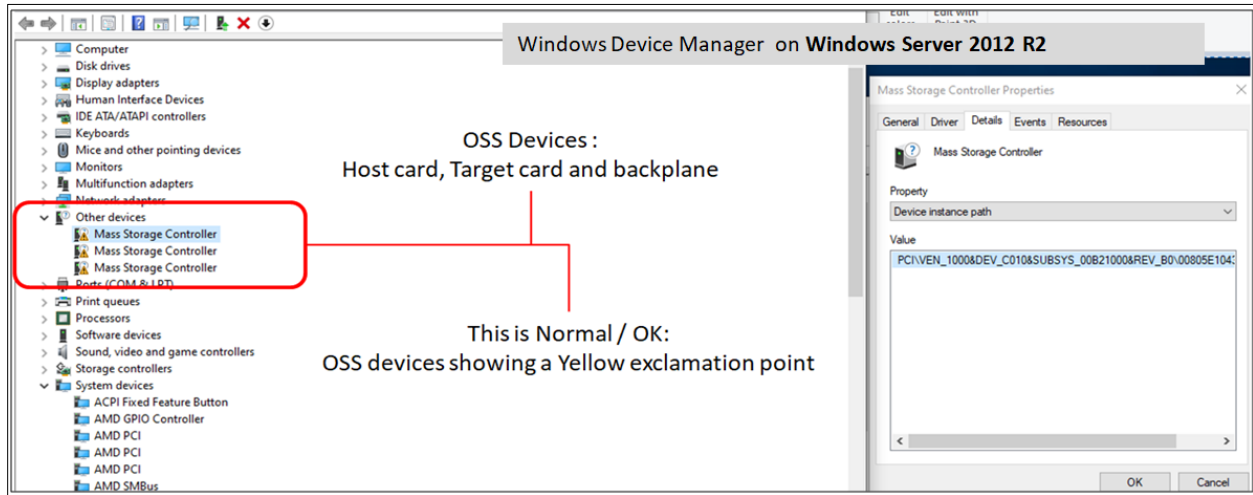

## 14 Verify PCIe cards

This section contains information on how to check / verify your PCIe cards are detected or not.

### 14.1 Linux

To check your PCIe cards use the following commands on the terminal window.

- **lspci -vtt** command. Output below is a screenshot of the “lspci -vtt” showing the OSS backplane with five cards installed.

OSS backplane populated with PCIe cards

```

+0c.0 Intel Corporation Xeon E7 v3/xeon E5 v3/Core i7 Power Control Unit
+1e.1 Intel Corporation Xeon E7 v3/xeon E5 v3/Core i7 Power Control Unit
+1e.2 Intel Corporation Xeon E7 v3/xeon E5 v3/Core i7 Power Control Unit
+1e.3 Intel Corporation Xeon E7 v3/xeon E5 v3/Core i7 Power Control Unit
+1e.4 Intel Corporation Xeon E7 v3/xeon E5 v3/Core i7 Power Control Unit
+1f.0 Intel Corporation Xeon E7 v3/xeon E5 v3/Core i7 VCU
+1f.2 Intel Corporation Xeon E7 v3/xeon E5 v3/Core i7 VCU
--(0000:80)---00.0-[81]---00.0 Intel Corporation L50 Gigabit Network Connection
|
+02.0-[82-a5]---00.0-[83-a5]---00.0-[84-a5]---00.0-[85-a5]---15.0-[86-a5]---00.0-[87-a5]---00.0-[88-9b]---00.0-[89-9b]---00.0-[8a-9b]---00.0-[8b-9b]
|
+00.0-[8c-8e]---00.0-[8d-8e]---10.0-[8e]---00.0 Solarflare Communications SFL9021 10GbASE-T Ethernet Controller
|
+04.0-[8f-92]---00.0-[90-92]---00.0-[91]---00.0 Intel Corporation 82574L Gigabit Network Connection
|
+10.0-[92]---00.0 NVIDIA Corporation GP106 [Quadro 400]
|
+08.0-[93-96]---00.0-[94-96]---00.0-[95]---00.0 NVIDIA Corporation GP106A [Quadro 600]
|
+0c.0-[97-9a]---00.0-[98-9a]---14.0-[99]---00.0 NVIDIA Corporation GP108 High Definition Audio Controller
|
+1c.0-[9a]---00.0 Broadcom / LSI Device c012
|
+0c.0-[9c-9f]---00.0-[9d-9f]---14.0-[9e]---00.0
|
+1c.0-[a0]---00.0 Broadcom / LSI Device c010
|
+0c.0-[a1-a4]---00.0-[a2-a4]---14.0-[a3]---00.0
|
+1c.0-[a5]---00.0 Broadcom / LSI Device c010
+04.0 Intel Corporation Xeon E7 v3/xeon E5 v3/Core i7 DPA Channel 0
+04.1 Intel Corporation Xeon E7 v3/xeon E5 v3/Core i7 DPA Channel 1
+04.2 Intel Corporation Xeon E7 v3/xeon E5 v3/Core i7 DPA Channel 2
+04.3 Intel Corporation Xeon E7 v3/xeon E5 v3/Core i7 DPA Channel 3
+04.4 Intel Corporation Xeon E7 v3/xeon E5 v3/Core i7 DPA Channel 4
+04.5 Intel Corporation Xeon E7 v3/xeon E5 v3/Core i7 DPA Channel 5
+04.6 Intel Corporation Xeon E7 v3/xeon E5 v3/Core i7 DPA Channel 6
+04.7 Intel Corporation Xeon E7 v3/xeon E5 v3/Core i7 DPA Channel 7
    
```

Output below shows four NVIDIA A100 are recognized.

```

44]---00.0-[33-44]---00.0-[34-44]---+00.0-[35-37]---00.0-[36-37]---10.0-[37]---
|
+04.0-[38-3b]---00.0-[39-3b]---+00.0-[3a]---00.0 NVIDIA Corporation GA100 [GRID A100 PCIe 40GB
|
|
+08.0-[3c-3f]---00.0-[3d-3f]---+00.0-[3e]---00.0 NVIDIA Corporation GA100 [GRID A100 PCIe 40GB
|
|
+0c.0-[40-43]---00.0-[41-43]---+14.0-[42]---
|
+1c.0-[44]---00.0 Broadcom / LSI Device c010
om / LSI Device c010
    
```

You can also grep the vendor name of the PCIe card. For example, if you have an NVIDIA GPUs, run the command on the terminal window “lspci -vvv | grep NVIDIA”.



The screenshot below shows an Ethernet card is detected and it installed in slot#1. The image below was captured on a computer running Windows Server OS.

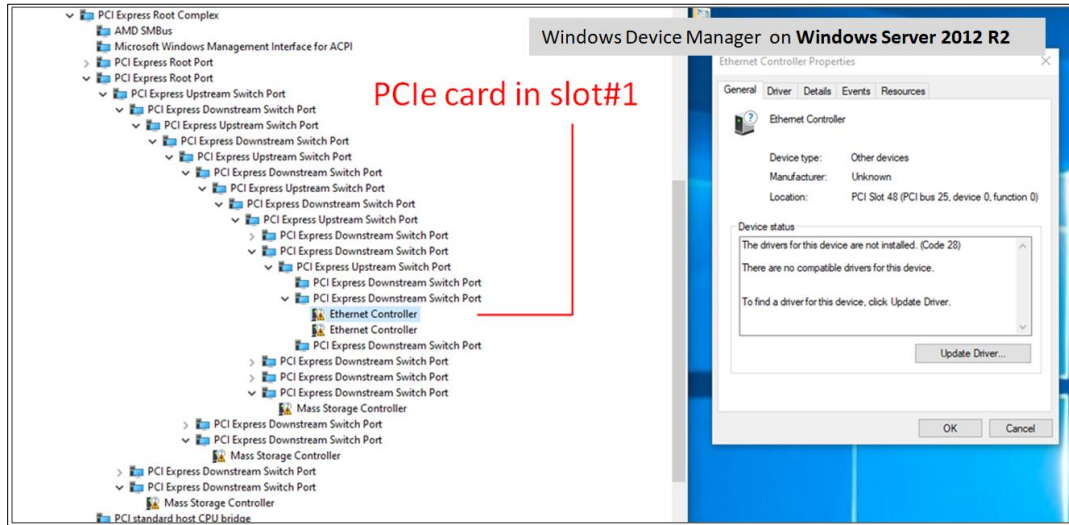

## 15 IPMI

IPMI is a configurable feature and it is not included with the base model. The IPMI module is installed during assembly. If you require this feature, select this option or contact your One Stop Systems sales representative at [sales@onestopsystems.com](mailto:sales@onestopsystems.com).

Unit equipped with IPMI, below photo shows the location of IPMI module installed in the unit.

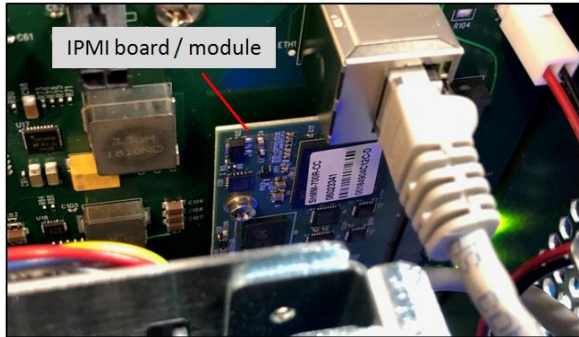

How to setup and access IPMI, follow instructions below.

### 15.1 Connect Ethernet Cables

1. Connect Ethernet cable to either front or back Ethernet port; you can only use one or the other. You must plug-in the Ethernet cable first before you connect the power to the unit.
2. Plug in the other end of the Ethernet cable to your network (running DHCP)

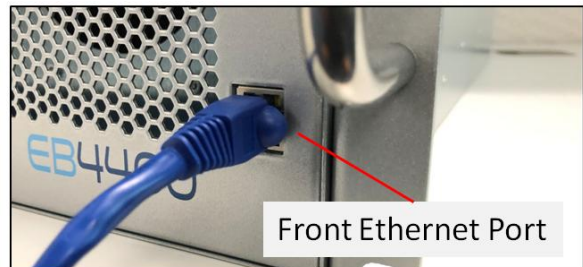
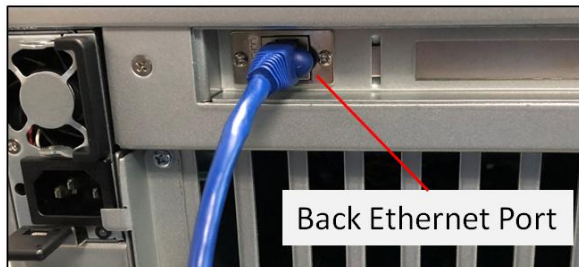

3. Connect the power cord on the back of the unit.



Upon connecting the power, the IPMI LED, will illuminate from solid red to blinking green and to solid green. When the led status is solid green, the IPMI is ready.

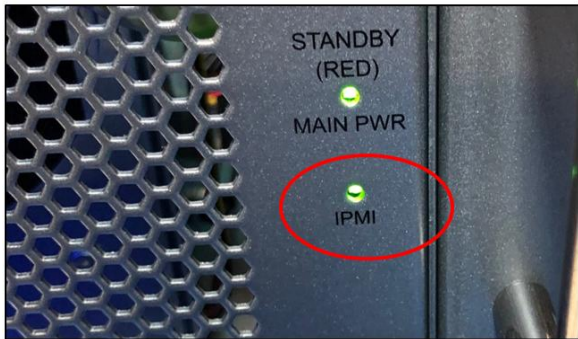

### 15.2 Locate Mac Address & IP Address

- Locate the Mac address sticker. Each Ethernet port will have a unique Mac address, the label will have the Mac address.
- If you don't see the label, check the IPMI module inside the unit that has a label containing the Mac address. The photo below shows the location of the label with the Mac address numbers.

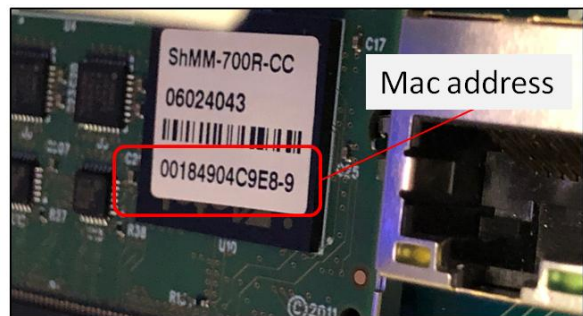
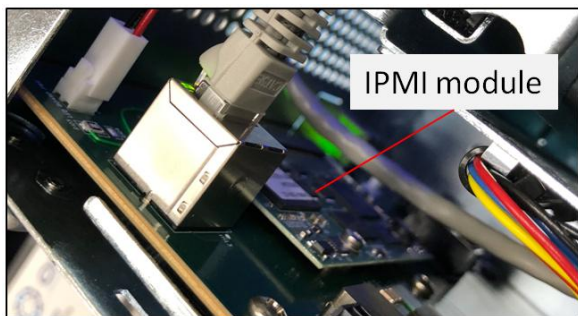

- There are two Mac addresses, one for each port. Below photo shows thirteen characters 00184904C9E8-9. The last digit is the designated number for the Ethernet port location on the unit.
- Based on the photo below, number 8 is for the back end Ethernet port. The last number 9 is for the front end Ethernet port. The number is unique for every module in the expansion unit.
- The Mac address for the front Ethernet is 00184904C9E9 (00:18:49:04:C9:E9 or 00-18-49-04-C9-E9).
- The Mac address for the back Ethernet port is 00184904C9E8 (00:18:49:04:C9:E8 or 00-18-49-04-C9-E8).

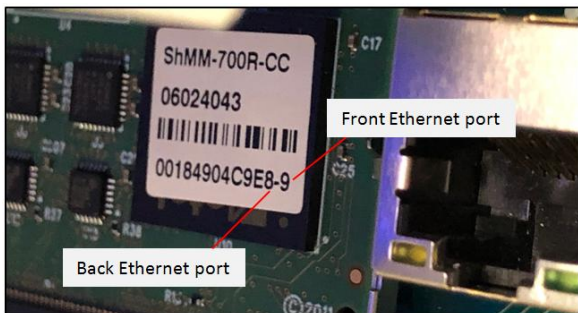

Use the Mac address to find the IP address assigned to that port over the network to access the IPMI web interface. You can use "arp -a" command on Windows and "arp -n" on Linux.

- From the output arp table, search for the Mac address of your IPMI module and match that to the assigned IP address
- Once you have identified the Mac address and the IP address, use the IP address to access the IPMI web interface.

Below photo is an example of Windows powershell cmdlet for querying the IP address using the Mac address.

```
PS C:\WINDOWS\system32> Get-NetNeighbor -LinkLayerAddress 00-18-49-04-c1-2c

ifIndex IPAddress                               LinkLayerAddress      State      PolicyStore
-----
7        192.168.1.153                                00-18-49-04-C1-2C    Reachable ActiveStore

PS C:\WINDOWS\system32> 2c is the Mac address for the back ethernet port
```

### 15.3 Start Internet browser

Launch your internet browser and type the IP address for example 192.168.1.153. Below photo is the Web interface of the IPMI monitoring the following hardware;

1. Fan status and speed
2. Backplane temperature
3. Power supply voltage and temperature



ADM1026 Internal Temperature Sensor	21C
-------------------------------------	-----

Fan 1 Status	OK
Fan 1 Speed	5100RPM

+3V3 STBY Voltage	3.3V
+3V3 MAIN Voltage	3.3V
+5VSB Voltage	5.1V
+12V Voltage	12V

PSU 1 Input Voltage	0V
PSU 1 Output Voltage	0.9V
PSU 1 Output Current	1A
PSU 1 Input Power	0W
PSU 1 Output Power	1W
PSU 1 Temperature 1	24C
PSU 1 Temperature 2	29C
PSU 1 Temperature 3	28C

Fan 2 Status	OK
Fan 2 Speed	5100RPM

Backplane 2 Temperature 1	25C
Backplane 2 Temperature 2	23C

PSU 2 Input Voltage	117V
PSU 2 Output Voltage	11.9V
PSU 2 Output Current	3A
PSU 2 Input Power	68W
PSU 2 Output Power	31W
PSU 2 Temperature 1	28C
PSU 2 Temperature 2	31C
PSU 2 Temperature 3	24C

## 16 Important Technical Information

### 16.1 Upstream and Downstream Slots

**Upstream Slot:** Also known as target slot. This is the designated slot for the Target adapter card. This slot is designed for the Target card only.

- Slot0 is the default Upstream slot.

**Downstream Slots:** These are PCIe card slots # 1, 2, 3, 4 and 5. You cannot use any of the downstream slots for Target card.

**Slot 5** can be programmed to operate as an Upstream slot or Downstream slot.

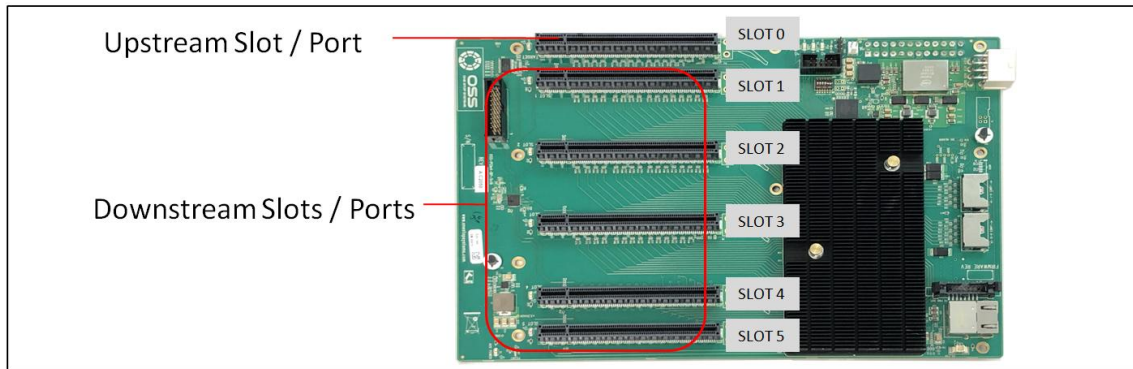

### 16.2 Slot LEDs

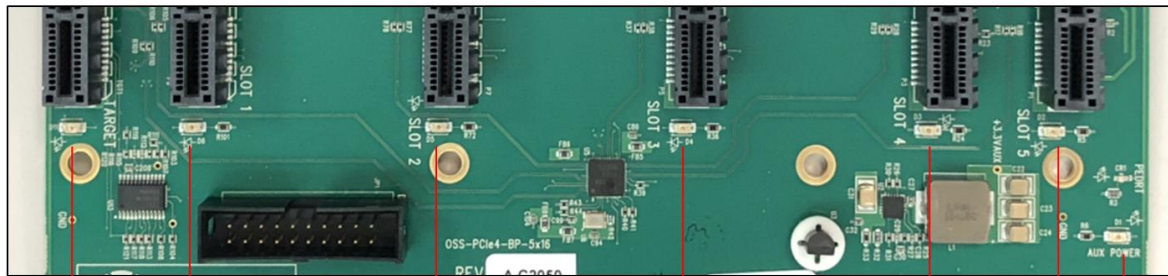

Target Slot LED

PCIe card slot LEDs

AUX Power LED

Item	Name	Description	When Lit (Solid Green or Blinking)	When Off
1	Target Slot LED	Upstream Slot LED	Solid = Gen4 Link	OFF - Not Linked / No Card present in the slot
			Blink 2Hz = Gen3 Link	
			Blink 1Hz = Gen2 Link	
			Blink 0.5Hz = Gen1 Link (Slow Blinking)	
2	Downstream LED	PCIe slot LEDs	Solid = Gen4 Link	OFF - Not Linked / No Card present in the slot
			Blink 2Hz = Gen3 Link	
			Blink 1Hz = Gen2 Link	
			Blink 0.5Hz = Gen1 Link (Slow Blinking)	
3	Aux Power LED	Auxiliary Board power LED	This is GREEN, denotes existence of auxiliary power +5VAUX	Board is at fault / error

### 16.3 Board LEDs

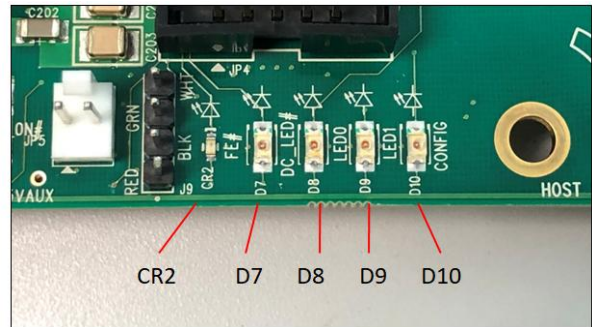

LED	Description
CR2	FE-Fault Error (SYS_ERROR#) LED
D7	PCIe slot LEDs Daisy Chain Port Link Status LED
D8	All Power Good
D9	FPGA Blinking LED (When FPGA code is loaded and working: 8 blinks, 2 pause counts, 8 blinks)
D10	Config output from the FPGA, but enabled as an FPGA option. When RED, board is not programmed. OFF, board is programmed.

### 16.4 Slot Type

Slot Type: Closed-ended PCIe slot / connector, x16 mechanical and x16 electrical Gen 4.

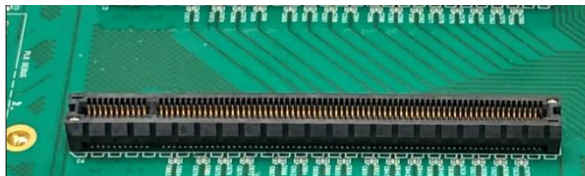

### 16.5 PS\_ON

A two-pin connector for a shunt / jumper, which allows the backplane to force power ON when the ATX supply is switched ON. See photos below for the location of the JP5 connector on the backplane.

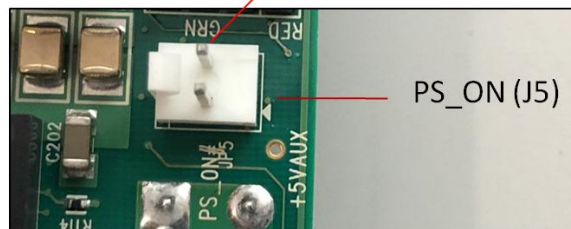

### 16.6 ARF6 Connector

ARF6 Connector - For connecting ARC6 cable to daisy chain two backplanes together and to create a bridge or connection between OPTION SLOT and the PCIe switch.

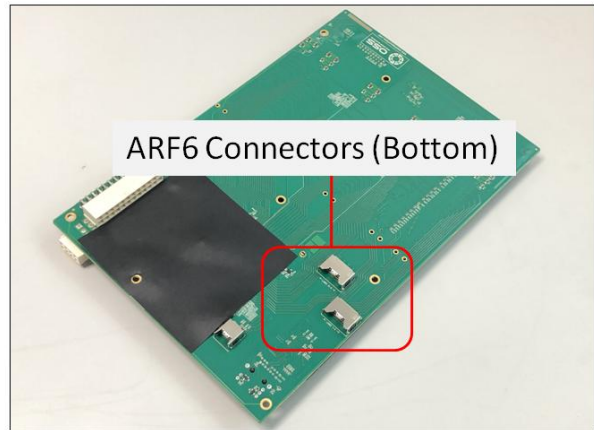
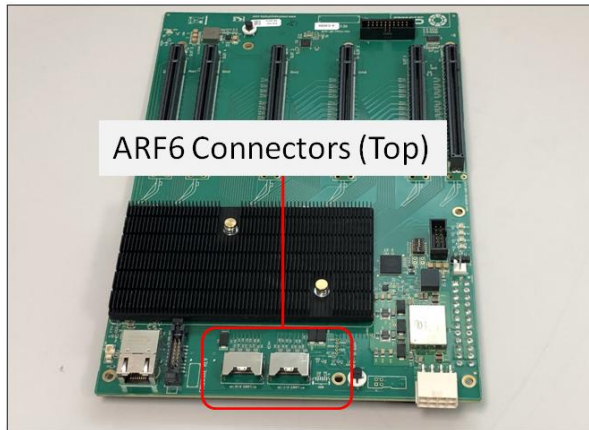

### 16.7 Slot Number and Port Mapping

Each slot on the OSS backplane is mapped to a PCIe port on the 88096 PCIe switch. Port mapping is hard-coded, it is essentially fixed. No means of changing or modifying it.

Port / Slot	Slot Mapping: 88096 Port
Slot 0	0
Slot 1	48
Slot 2	64
Slot 3	80
Slot 4	32
Slot 5	16 (Daisy chain) If slot 5 is cabled to the daisy chain port, it becomes port 16 of the 88096 (regardless of upstream/downstream configuration).NA: If not enabled, no port assignment

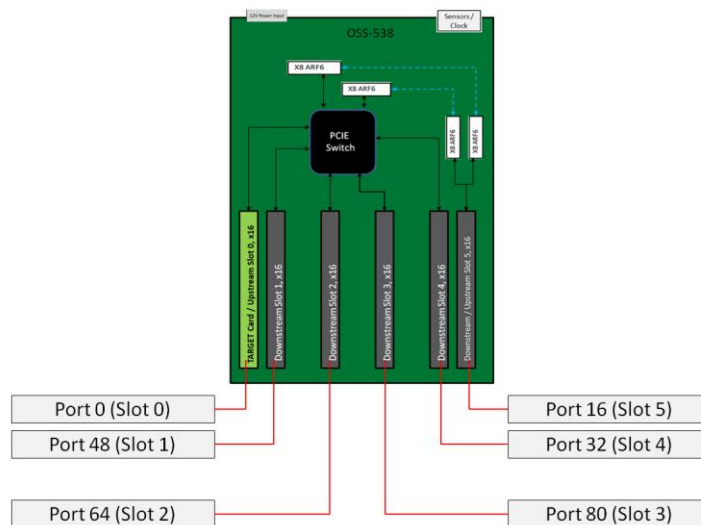

### 16.8 Power Cords

Two types of power cords can be used with this expansion unit, 125V and 250V. This is only applicable to AC power supplies



#### 16.8.1 Specifications

OSS PART#: 290-001-012-RC (125V)		OSS PART#: 290-001-032-RC (250V)	
Description: CORD NEMA5-15P C-13SJT		Description: CORD PWR MALE-FEMALE SJT	
Part Status	Active	Part Status	Active
Style	Male pins (Blades) to Female Sockets (slots)	Style	Male pins (Blades) to Female Sockets (slots)
1 <sup>ST</sup> Connector	NEMA 5-15P	1 <sup>ST</sup> Connector	IEC 320-C14
2 <sup>ND</sup> Connector	IEC 320-C13	2 <sup>ND</sup> Connector	IEC 320-C13
Number of Conductors	3	Number of Conductors	3
Cord Type	SJT	Cord Type	SJT
Wire Gauge	14 AWG	Wire Gauge	14 AWG
Shielding	Unshielded	Shielding	
Approval Marks	CSA, UL	Approval Marks	CSA, UL
Approved Countries	Canada, USA	Approved Countries	
Voltage Rating	125V	Voltage Rating	250V
Current Rating	15A	Current Rating	15A
Operating Temperature	60°C	Operating Temperature	105°C
Digi-Key Part#	Q944-ND	Digi-Key Part#	1175-1312-ND

#### 16.8.2 Power cord socket and voltage tables

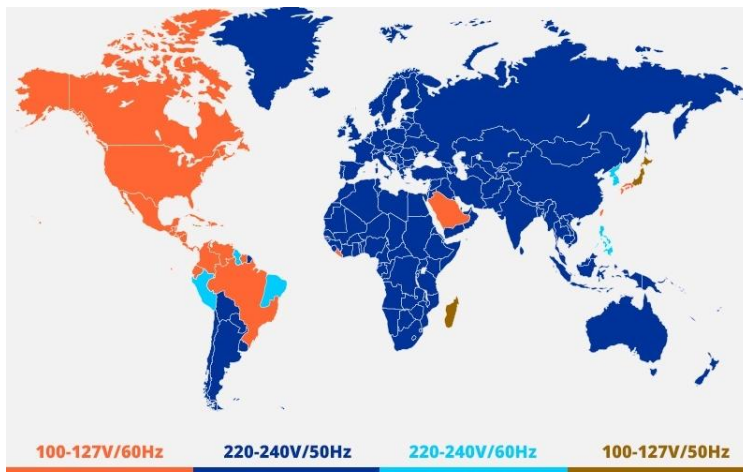

## 16.9 Power Supply

### Power Options

- Single/Dual AC 1600W
- Single/Dual DC 1600W

### AC Power Supply



### DC Power Supply



Standard or base model 4UP00 unit comes with one or two replaceable AC power supply modules (ea 1600 W)

- With two power supply modules installed:
  - Share the power load requirements during normal operations.
  - Should one module fail for any reason, the power load will be shifted to the other module.
- LED indicator to keep you informed on normal/abnormal conditions for your PSU.
  - An indicator for the failure would be the LEDs on the back panel of the power supply behind the chassis.
  - For non-functioning equipment, these indicators would not show

### 16.9.1 Removing AC Power Supply

1. Disconnect the power cord from the power supply you are removing.
2. Grasp the power-supply handle.
3. Press the black release latch **upward** and hold it.
4. Pull the power supply out of the bay.

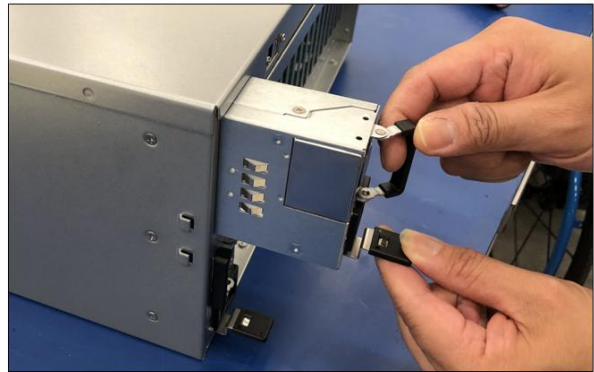
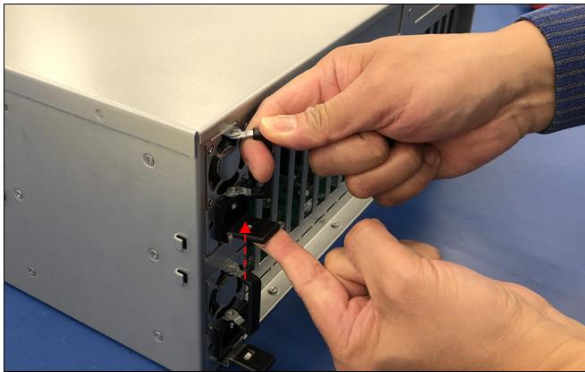
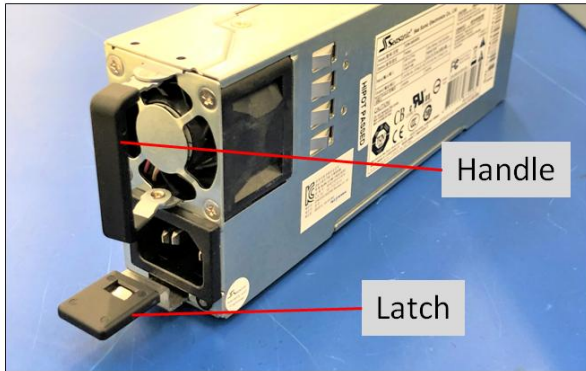

## 16.9.2 Specifications

### Input Rating

The power supply shall operate within all specified limits over the following input range. Harmonic distortions of up to 10% of the rated line voltage must not cause the power supply to go out of specified limits.

The power supply shall power off if the AC input is below VAC<sub>low\_limit</sub> and shall start (auto recovery) if the VAC<sub>recover</sub> is reached. Input of VAC below VAC<sub>recover</sub> shall not cause any damage to the power supply, including the input fuse. The power supply shall also operate at Vin 240Vdc.

Parameter	Minimum Input	Rated Input	Maximum Input
115Vac	90Vac	100-127Vac	140Vac
230Vac	180Vac	200-240Vac	264Vac
Frequency	47Hz	50/60Hz	63Hz

#### 240VDC Input Rating

PARAMETER	MIN	RATED	MAX
Voltage	192VDC	240VDC	288VDC
Current	10A	8.5A	

### Maximum Input Current

Input Voltage	Input Current	Maximum Power
90Vac	15A	1000W
100-127Vac	13~10A	1000W
140Vac	9A	1000W
180Vac	11.5A	1600W
200-240Vac	10~8.5A	1600W
264Vac	7.5A	1600W

### Output Rating

GROUP	1		2
OUTPUT VOLTAGE	+12V		+12VSB
INPUT VOLTAGE	100~127Vac	200~240Vac	100~240Vac
MAX.LOAD	83.3A	133.3A	2.1A
CLST Peak 20sec duration *	89.3A	139.3A	2.4A
Pmax.app Peak 10msec duration *	103.3A	153.3A	
Pmax Peak 100µsec duration *	128.3A	178.3A	
MIN.LOAD	0A		0A
VOLTAGE REGULATION	±5%		±5%
RIPPLE & NOISE	120mV		120mV
Max. Capacitive Loads	5000µF		3100µF
Min. Capacitive Loads *	2000µF		10µF
Dynamic Load Capacitive Load	2000µF		20µF

### 16.9.3 LED Indicator

Power Supply Condition	LED State
Output ON and OK	GREEN
No AC power to all power supplies	OFF
PSU standby state AC present / Only 12VSB on	1Hz Blink GREEN
Power supply is cold standby state or always standby state as defined in the Cold Redundancy section of the CRPS Common Requirements Specification	1Hz Blink GREEN
AC cord unplugged or AC power lost; with a second power supply in parallel still with AC input power.	AMBER
Power supply critical event causing a shutdown; failure, over current, short circuit, over voltage, fan failure, over temperature	AMBER
Power supply warning events where the power supply continues to operate; high temp, high power, high current, slow fan.	1Hz Blink Amber
Power supply FW updating	2Hz Blink GREEN

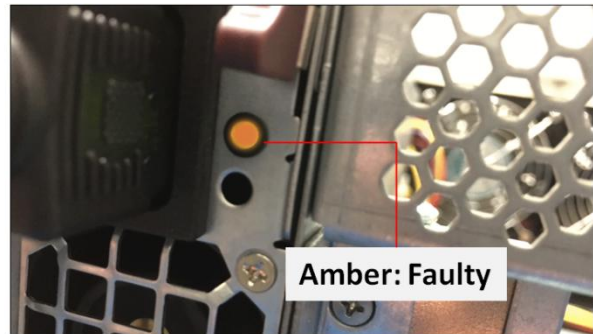
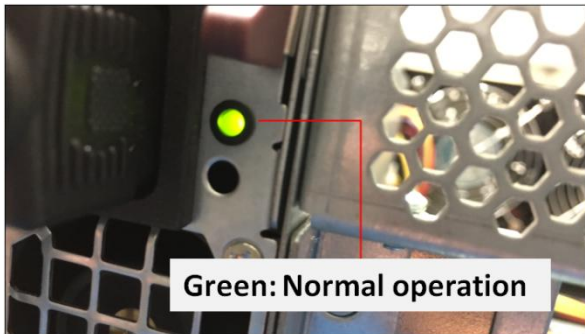

## 16.10 Fan

The expansion unit has two fans installed with sufficient capacity to provide cooling to the extreme-high-heat- generating GPUs. These are high CFM / RPM replaceable fans. The fans have a PWM controlled fan speed (4x lead wires), regulated by the temperature sensors within the system

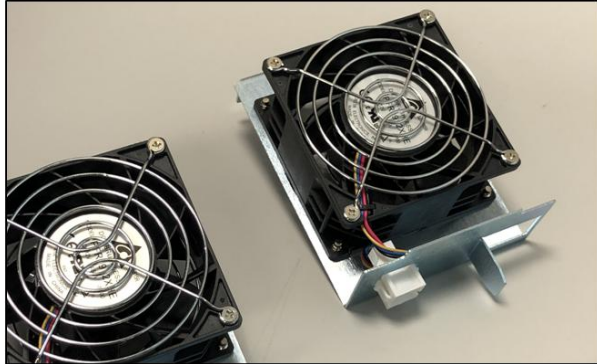

### 16.10.1 Fan Specifications

Series	PFR	Power (Watts)	44.40W
Part Status	Active	RPM	11500RPM
Voltage Rated	12 VDC	Termination	4 Wire Leads
Size / Dimension	Square-92mm L X 92mm H	Ingress Protection	--
Width	38.00mm	Operating Temperature	-10--+70°C
Air Flow	185.55CFM (5.255 m3/min)	Weight gram (g)	260g
Static Pressure	2.523inchH2O (64.10mmH2O)	Current Rating	3.70A
Bearing Type	Ball	Voltage Rating	07.0-13.2VDC
Fan Type	Axial	Material Frame	Plastic
Features	Speed Sensor (Tach), PWM control	Material Blade	--
Noise	71.0dB(A)	Lifetime @ Temp	70000 Hrs@40°C

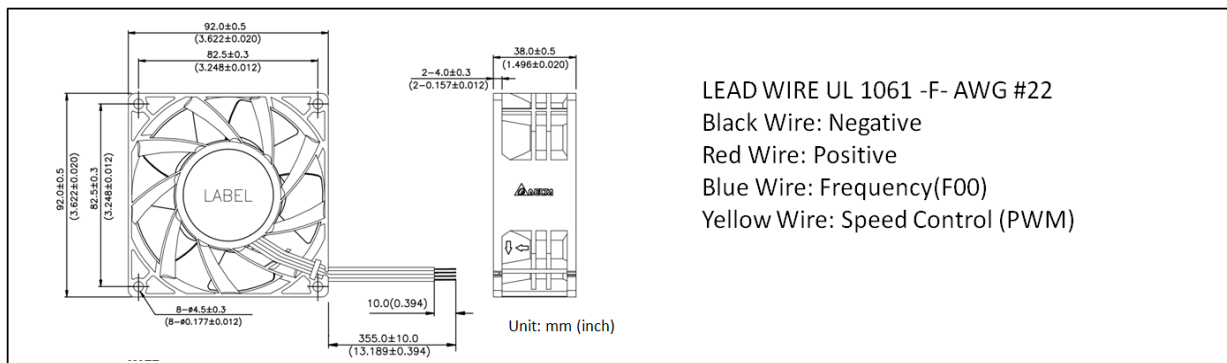

### 16.10.2 How to remove Fan

Loosen the thumbscrew and slowly pull the fan out, see photos below.

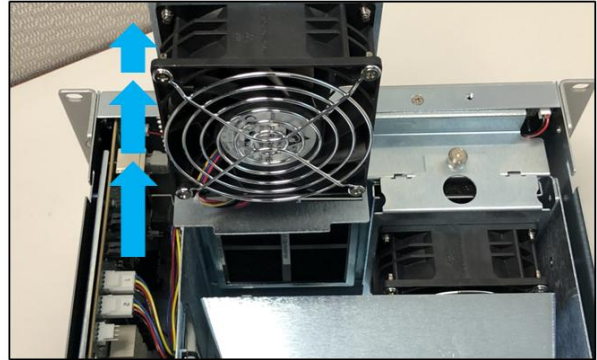
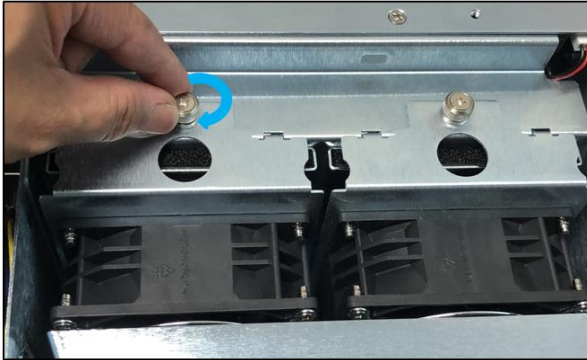

### 16.11 Fan Foam Air Filter

The 4UP can be configured to come with fan foam air filters with minimal airflow resistance to prevent dust from entering the expansion unit. You can easily remove and clean the filter. To access the foam air filter, simply remove the fan first and pull the filter out, see photos below.

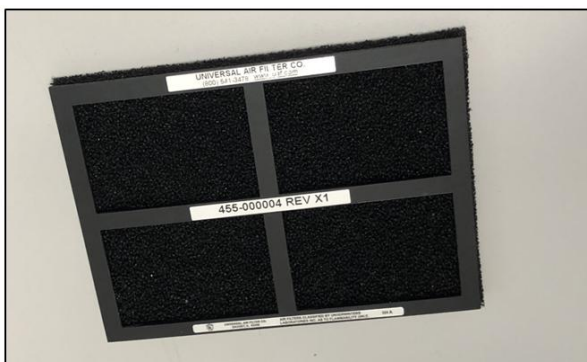
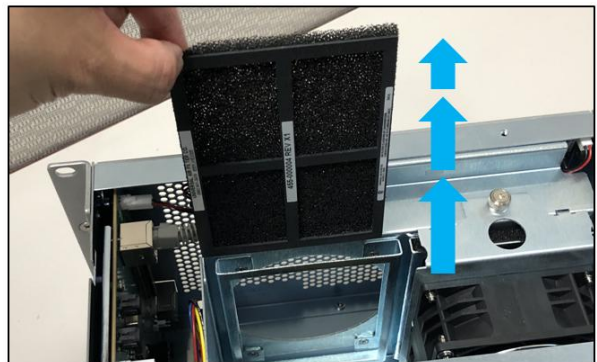





### 16.12 Auxiliary power cables

Auxiliary power cables are available for the unit but are not included. They are optional and sold separately. If your card requires an auxiliary power, please contact our Sales team.

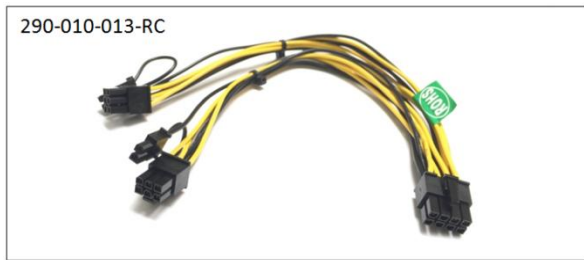
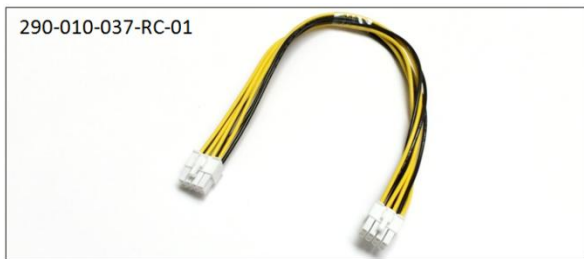
There are two different sets of aux power cables, see table below.

Aux Power Cable	Part Number	Description	Connector	#of Connector
8 pin	290-010-037-RC-01	Cable Assy, Aux Pwr, 8 Pin, NVIDIA 2.0, 12", Expansion System, M176 (OSS)	8-pin male to 8-pin male	One 8-pin connector
	290-010-037-RC-02	Cable Assy, Aux Pwr, 8 Pin, NVIDIA 2.0, 24" Expansion System, M176 (OSS)	8-pin male to 8-pin male	One 8-pin connector
6+2 pin	290-010-013-RC	Cable Assy, Canister, External Pwr, Dual 6+2 PCIe Graphics Only	8-pin male to 2 6+2-pin male	Two 6+2 pin connectors
	290-010-036-RC	Cable Assy, Aux Pwr, 6+2 Pin, 24", Expansion System, M176 (OSS)	8-pin male to 2 6+2-pin male	Two 6+2 pin connectors



	Connectors	Can provide power of
	8 pin	150 Watts
	Two 6+2 pin	300 Watts
	6 pin	75 Watts

### 16.12.1 Aux power cable installation

The auxiliary power is supplied directly from the power supply backplane and there are 10 available AUX power connections / ports in which the auxiliary power cables are plugged in, see photo below.

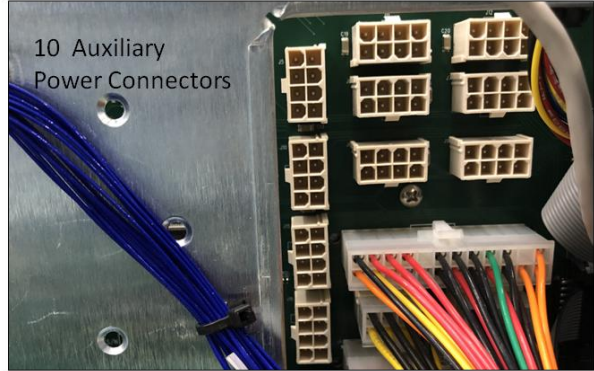
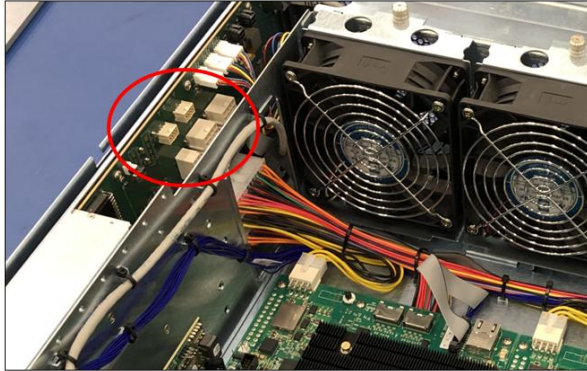

To plug in the 6+2 pin cable correctly, connect the **Y** end connector of the cable to the power distribution board, see photos below.

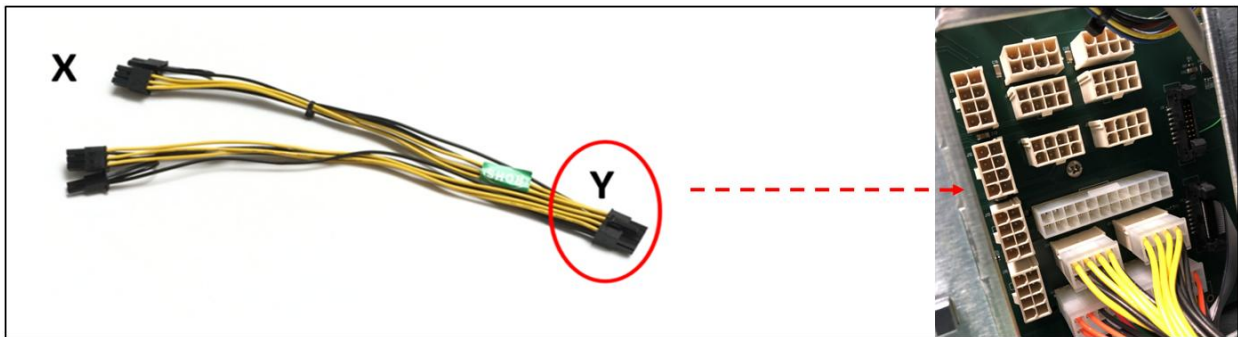

To plug in the 8-pin cable correctly, you can use either **X** or **Y** end of the cable, see photos below.

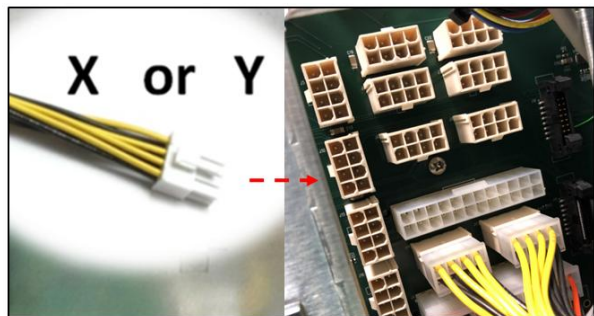

Ensure the cable is fully seated and secured.



**NOTE**

Route cables away from FANs. For safety and proper airflow avoid blocking the fans.

### 16.12.2 Pin Outs

PSU board aux port pin outs

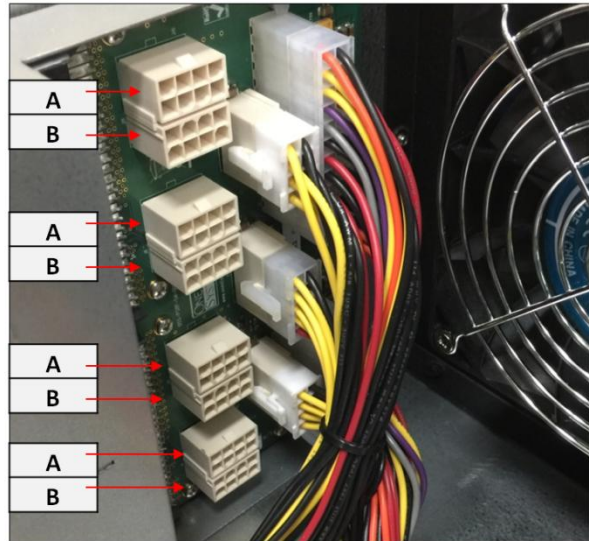
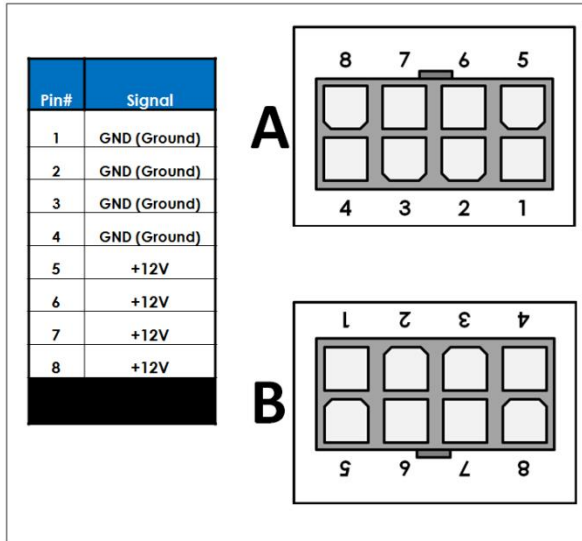

8-pin aux power cable and pin outs

Figure A1

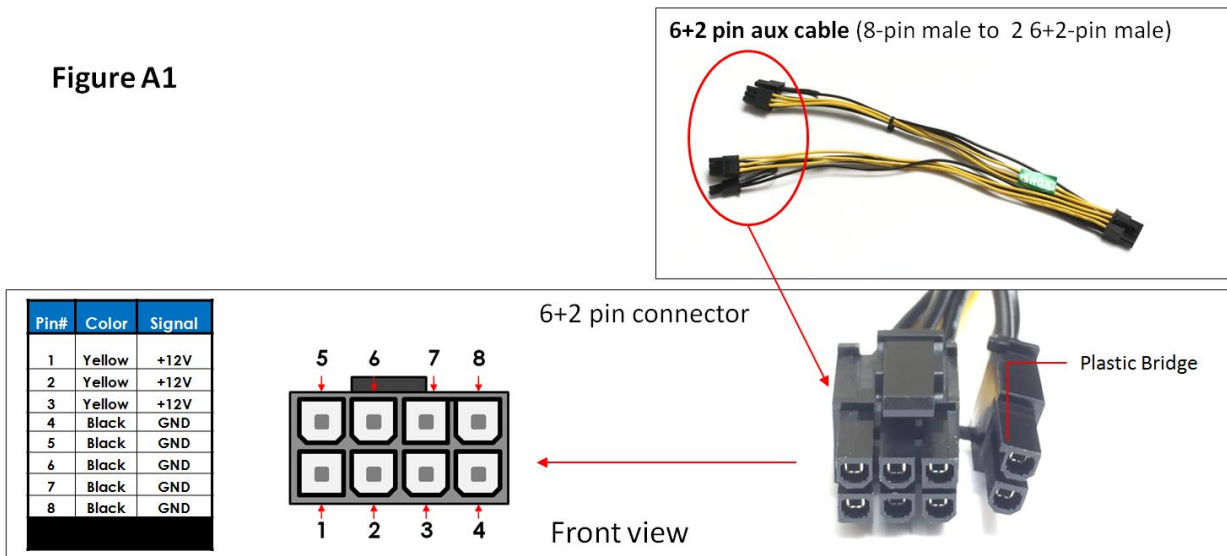
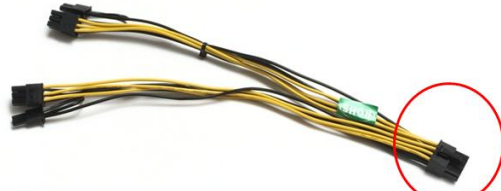
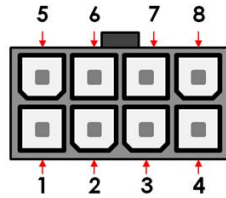

Figure A2

6+2 pin aux cable (8-pin male to 2 6+2-pin male)



Pin#	Color	Signal
1	Black	GND
2	Black	GND
3	Black	GND
4	Black	GND
5	Yellow	+12V
6	Yellow	+12V
7	Yellow	+12V
8	Yellow	+12V



8-pin connector

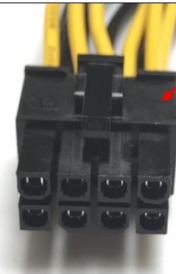

Front view

6+2-pin aux power cable and pin outs

Figure B1

8-pin aux cable (8-pin male to 8-pin male)

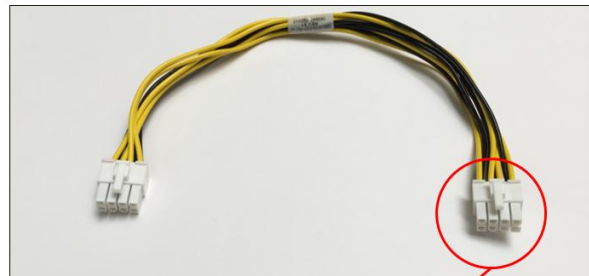

Pin#	Color	Signal
1	Black	GND
2	Black	GND
3	Black	GND
4	Black	GND
5	Yellow	+12V
6	Yellow	+12V
7	Yellow	+12V
8	Yellow	+12V

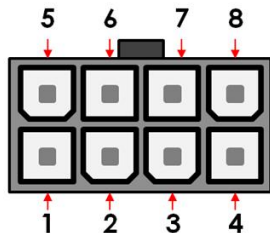

8-pin connector



Front view

Figure B2

8-pin aux cable (8-pin male to 8-pin male )

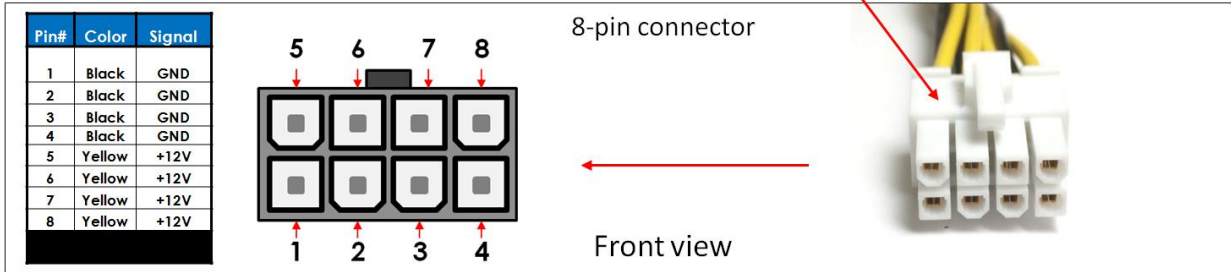
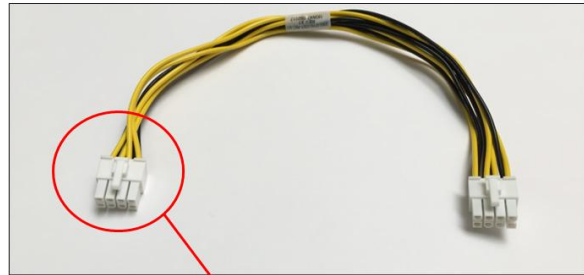

### 16.12.3 Using the Auxiliary Power Cable

When using a PCIe card such as FPGA GPU cards that requires additional power, you may need auxiliary power cables . Depending on the power requirement of your PCIe card, it will have a different built-in aux power port in which you attach the aux power cable.

A PCIe slot provides 75 watts of slot power, which is not enough to meet the power requirement for a high-end add-in card with power consumption. A direct connection to the power system is needed to obtain additional power. This can be done by using the 6+ 2 pin or 8 pin auxiliary power cables. The below photos represent how the 6+2 pin connector and 8 pin aux power cables are attached to the PCIe card or GPU card.

The photo below is an example of a PCIe card or GPU card that has two 6-pin power connectors.



The photos below are example of a PCIe card or GPU card that has a 6pin power connector. You need one 6+2pin aux cable to provide extra power.





FPGA card



The photo below is an example of a PCIe card that has an 8pin power connector. You need one 8-pin aux cable to provide extra power.

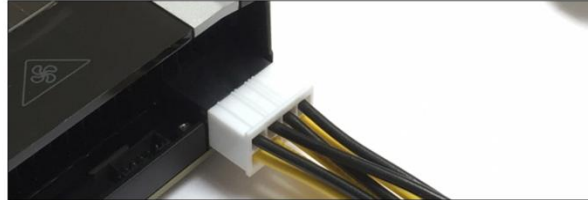
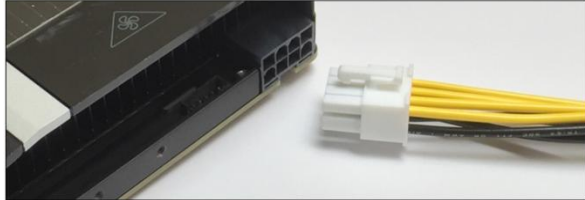

Each PCIe x16 slot on the 522 OSS board provides 75 Watts of power which is adequate for most video cards. But a high-end GPU cards usually need more power. To accommodate graphics cards needing more than 75 watts, the **PCI-SIG (Special Interest Group)** introduced two standards for supplying additional power to a video card via additional graphics power connectors:

- **PCI Express x16 Graphics 150 W-ATX Specification**—Published in October 2004, this standard defines a six-pin (2x3) auxiliary power connector capable of delivering an additional 75 W to a graphics card directly from the power supply, for a total of 150 W to the card.
- **PCI Express 225 W/300 W High Power Card Electromechanical Specification**—Published in March 2008, this standard defines an eight-pin (2x4) auxiliary power connector capable of supplying an additional 150 W of power, for a total of either 225 watts (75+150) or 300 watts (75+150+75) of available power.

Graphics Card Auxiliary Power Connector Configurations	
Maximum Power Draw	Auxiliary Power Connector Configuration
75 Watts	None
150 Watts	One six-pin connector
225 Watts	Two six-pin connectors*
300 Watts	One eight-pin connector + one six-pin connector
375 Watts	Two eight-pin connectors
450 Watts	Two eight-pin connectors + one six-pin connector

\*May optionally use one eight-pin connector instead

**GPU Card Power Connectors**

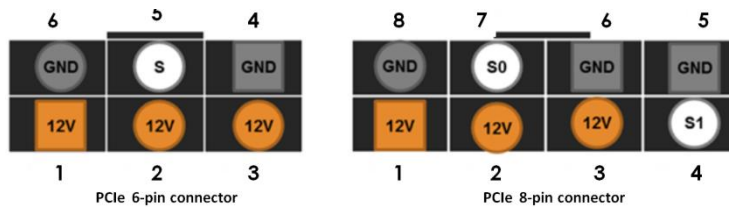

Pin	6-pin	8-pin
1	12V	12V
2	12V	12V
3	12V	12V
4	GND	SENSE1
5	SENSE	GND
6	GND	SENSE0
7	--	GND
8	--	GND

Example below, when using a GPU card that has a maximum power consumption of 300 Watt. It has an 8-pin and 6-pin power connectors.

Number of Pins	Watt
6 pin connector	provides 75 Watts
8 pin connector	provides 150 Watts

To provide additional power, you need two 6+2pin cable connectors, see Figure A.

Note:300 Watt power needed = 75 Watt from PCIe slot + 75 Watt from 6-pin + 150 Watt from 8-pin.



Figure B shows the wrong power cable to use due to special keying on the eight-pin connector. The GPU power connector has a different keying to prevent interchanging with the +12 V power connectors.

NOTE: We do not provide different aux power cables (i.e. 8pin to 4pin Molex) other than what we offer. If your PCIe card requires a different power adapter or aux power cable, you would have to buy it from other electronic stores.

### 16.13 Expansion Unit Power Consumption

The EB4400 expansion unit draws a maximum of 304 Watts (2 Fans + 1Backplane + 1Interface board + IPMI board) of power without any boards / cards installed.

### 16.14 Power consumption breakdown per hardware

Item	Hardware	Power Consumption
1	Target Card OSS Gen 4	60 Watts
2	Fans	88.80 Watts (44.40 Watt per fan)
3	Backplane	150 Watt per backplane
4	IPMI board	6 Watts

## 17 Troubleshooting

### 17.1 Device is not detected or recognized

1. Shutdown the system
2. Disconnect the cables
3. Disconnect the power from the unit
4. Remove the HIB card from the unit and host computer
5. Re-insert the HIB card
6. Reconnect the cables
7. Turn ON the unit

### 17.2 My PCIe devices are showing UP with a Yellow Exclamation mark

1. Obtain the software / driver from the 3<sup>rd</sup> party vendor.
2. Install or re-install the driver
3. Reboot the system after installing the driver

### 17.3 No link between host and target cards

1. Check the dipswitches on each card. Make sure the Target card is set to target mode and Host card is set to host mode.
2. Check the Target card is installed in the target slot / upstream slot.
3. Use a validated / certified OSS HIB Cable adapter Gen4 cards
4. Reseat the Cables. Makes sure you are using a Gen4 cables.
5. Swap or replace the host card, target card and Link cables.
6. If you are still having the same issue after replacing the host card, target card and cables, your next step is to replace the backplane with a known good board or contact Technical Support for assistance.

### 17.4 Broken OSS-Backplane

1. If you received a brand new DOA (Dead on Arrival) board, please contact OSS to RMA board and request for a replacement.
2. If you have an out of warranty board, please contact OSS Sales team and buy a new replacement board.
  - Standard warranty is 1 year, unless you have an SLA or extended warranty coverage.
3. If you purchased a second-hand / used board and it is broken, please contact OSS Sales team to buy a replacement.
  - Note: Purchasing a second-hand / used product is not covered under warranty.

### 17.5 My PCIe cards are not detected

Both Target and Host cards are linked, the LINK LED on both cards are illuminated and all the LED indicators on the cards are working. However, the Operating System is not recognizing all of my PCIe cards that are installed on the backplane.

1. Check the Dip switches on the backplane make sure they are set correctly, see photos below for the correct settings.

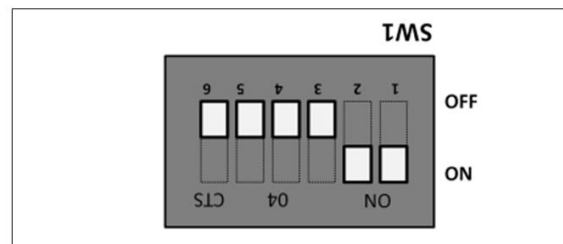
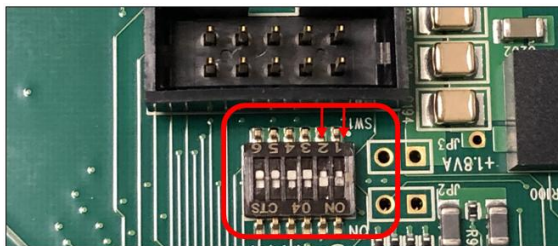

## 18 How to Get More Help

You can visit the Technical Support FAQ pages on the Internet at <https://www.onestopsystems.com/support>

### 18.1 Contacting Technical Support

Our support department can be reached by phone at [1 \(760\) 745-9883](tel:17607459883). Support is available Monday through Friday, 8:00 AM to 5:00 PM PT. When contacting Technical Support make sure to include the following information:

1. Exact and correct serial #
2. Service Ticket or Case # (if you already submitted an online request)
3. Computer Type & Model: Operating System
4. Make & Model of PCI/PCIe cards: Application
5. Problem description

When submitting an online technical support request always provide a valid working e-mail address, phone number, shipping address and proper contact name. Check your e-mail for an automated response containing the case # and updates. You can also visit our web site at: <https://www.onestopsystems.com/support> for a quick response, use the Technical Support and RMA Request Form available in the Support Section of the website. Simply complete the form with all required information. Please make sure that your problem description is sufficiently detailed to help us understand your problem.

#### Shipping or Transporting of Expansion Unit with PCI / PCIe cards

Any PCIe cards in **should be removed** (or not to be installed) prior to shipment to avoid or prevent possible damage. Note: Expansion board and PCIe / PCI cards that arrive damaged in shipment will not be covered under warranty.

### 18.2 Returning Merchandise

If factory service is required, a Service Representative will give you a Return Merchandise Authorization (RMA) number. Put this number and your return address on the shipping label when you return the item(s) for service. Please note that One Stop Systems WILL NOT accept COD packages, so be sure to return the product freight and duties-paid. Ship the well-packaged product to the address below:

Attention:RMA # \_\_\_\_\_, One Stop Systems  
2235 Enterprise Street, #110  
Escondido, CA 92029  
USA

It is not required, though highly recommended, that you keep the packaging from the original shipment of your product. However, if you return a product for warranty repair/ replacement or take advantage of the 30-day money back guarantee, you will need to package the product in a manner similar to the manner in which it was received from our plant. We cannot be responsible for any physical damage to the product or component pieces of the product (such as the host or expansion interfaces for the expansion chassis) that are damaged due to inadequate packing. Physical damage sustained in such a situation will be repaired at the owner's expense in accordance with Out of Warranty Procedures. Please, protect your investment, a bit more padding in a good box will go a long way to insuring the device is returned to use in the same condition you shipped it in. Please call for an RMA number first.

### 18.3 Third Party Hardware & Software Support Policy

OSS tests, certifies and bundles many popular third party hardware and software products with OSS hardware for ease of use and guaranteed operation. OSS encourages customer innovation by combining OSS products in new and interesting ways with third party and customer developed hardware and software. Unfortunately, with virtually infinite combinations of hardware and software, OSS cannot test and validate every possible configuration. OSS is committed to supporting its products and identifying if any technical issue may be related to third-party hardware or software. In order to isolate technical issues, OSS may request that the system be returned to the same configuration that shipped from the OSS factory and any non-OSS supplied third-party hardware or software be removed from the system during troubleshooting.

We test, certify and support many third party hardware and software products along with OSS hardware and are happy to integrate a fully supported system. Ask us about that service and we would be happy to help. If an OSS product is fully functional and a support issue is related to third-party hardware or software that did not ship from the OSS factory, the customer requesting support should reach out to the third-party vendor for assistance to fully troubleshoot the issue.

### 18.4 Online Support Resources

If you need technical support, product assistance or have a technical inquiry we encourage you to submit it on-line using our Technical Support Form: <https://www.onestopsystems.com/support>



**2235 Enterprise Street, Suite#110, Escondido CA 92029**

Toll-Free : +1(800)285-8900 US • Main: +1 (760) 745-9883 • Fax: +1 (760) 745-9824

**[www.onestopsystems.com](http://www.onestopsystems.com)**